

# Service Manual

[TOP NEXT](#)

ORDER NO. VRD0202007C2

# Service Manual

Video Cassette Recorder



1 NV-FJ730EG/NV-FJ730B/NV-FJ730EC/NV-FJ732EE

Z-MECHANISM

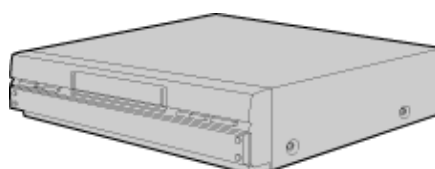

## SPECIFICATIONS

ITEM	SPECIFICATION	ITEM	SPECIFICATION	
POWER	SOURCE: 220-240 V AC 50/60 Hz	VIDEO	OUTPUT: EURO AV (AV1/AV2) Connector (21 pin) 1.0 Vp-p, 75 Ω terminated	
	CONSUMPTION: 18 watts CONSUMPTION WHEN IN STANDBY MODE: Approx. 3W (NV-FJ730EG/EC, 732EE)		HEAD: 1 Stationary head (Normal-mono) 2 channels (Hi-Fi/Stereo)	
RECORDING SYSTEM	2 rotary heads, helical scanning system PAL	AUDIO	INPUT: EURO AV (AV1/AV2) Connector (21 pin) More than -6dBV (500 mV), 10 kΩ AUDIO IN (AV3-FRONT) Connector (Phono type) More than -6dBV (500 mV), 10 kΩ	
TV TUNER SYSTEM	NV-FJ730EG/EC		OUTPUT: AUDIO Connector (Phono type) -6 dBV (500 mV), Less than 1kΩ EURO AV (AV1/AV2) Connector (21 pin) -6 dBV (500 mV), Less than 1kΩ	
	NV-FJ730B			
	NV-FJ732EE	VHF: CH2-CH12 (PAL/SECAM B) CHA-CH2 (ITALY) (PAL/SECAM B) UHF: CH21-CH69 (PAL/SECAM G) CATV: CH501-CH541 (PAL/SECAM B)	TAPE SPEED	SP: 23.98 mm/s LP: 11.695 mm/s SL: 7.96 mm/s Playback Time: SP: 4 hours with 240 min. type tape LP: 8 hours with 240 min. type tape SL: 12 hours with 240 min. type tape REWIND Time: 60 sec. with 180 min. type tape
RF OUT SYSTEM	NV-FJ730EG/EC		OPERATING TEMPERATURE	5°C - 40°C
	NV-FJ730B	VHF: CH2-CH12 (PAL/SECAM B) CHR1-CHR12 (SECAM D) UHF: CH21-CH69 (PAL/SECAM G, SECAM K, PAL I) CATV: CH501-CH541 (PAL/SECAM B) 44MHz-470MHz (SECAM B)	OPERATING HUMIDITY	35% - 80%
	NV-FJ732EE	UHF: CH21-CH69 (PAL/SECAM G) 71 ± 3 dBμ, 75 Ω, close	DIMENSIONS	430 (W) × 87 (H) × 282 (D) mm
VIDEO	HEADS: 4 rotary heads 1 pair for recording and playback (L-R heads) 1 pair for trick play (L-R heads)	WEIGHT	3.5 kg	
	INPUT: EURO AV (AV1/AV2) Connector (21 pin) 1.0 Vp-p, 75 Ω terminated VIDEO IN (AV3-FRONT) Connector (Phono type) 1.0 Vp-p, 75 Ω terminated	STANDARD ACCESSORIES	1 pc. DIN-RF Cable 1 pc. AC Mains Lead 1 pc. Infra-red Remote Controller	

Weight and dimensions shown are approximate.  
Specifications are subject to change without notice.

© 2002 Matsushita Electric Industrial Co., Ltd. All rights reserved. Unauthorized copying and distribution is a violation of law.

### WARNING

This service information is designed for experienced repair technicians only and is not designed for use by the general public. It does not contain warnings or cautions to advise non-technical individuals of potential dangers in attempting to service a product. Products powered by electricity should be serviced or repaired only by experienced professional technicians. Any attempt to service or repair the product or products dealt with in this service information by anyone else could result in serious injury or death.

# Panasonic

[TOP NEXT](#)

## 2.1.1 REPLACING IC7702/EEPROM

[TOP](#) [PREVIOUS](#) [NEXT](#)

When the EEPROM: IC7702 is replaced, applicable model code, option code and electrical adjustment data will not be available.

Therefore, enter and/or adjust the necessary data after replacing IC7702 by referring following procedure.

### STEP1.REPLACE THE IC7702

1. Remove the C.B.A. with Mechanism unit by referring the Disassembly procedure.
2. Disconnect the AC plug and replace the IC7702.

### STEP2.INPUT THE MODEL & OPTION CODE

1. Set up the applicable model code and option code by ordering the following table.







PROCEDURE	F.L.P. DISPLAY
<b>Turn on the Service Mode</b> 1.Press the FF key and the EJECT key simultaneously for more than 3 seconds.	
<b>Activate the Service Mode 2</b> 2.While keep placing FF key, press the EJECT key in twice.	
<b>Activate the Entering Mode.</b> 3.Press the EJECT key for more than 3 seconds.	
<b>Set the Mode 2.</b> 4.Press the CH UP key in twice.	
<b>Display the Setting Code.</b> 5.Press the POWER Button to turn the power on.	 (Colon starts flashing)
<b>Enter the Model and Option Code.</b> 6.Service Screen is displayed on the monitor. 7.Set the applicable Model and Option code by using REW, PLAY, STOP and FF keys on theRemote Controller. (See Fig.S1 & S2)	
<b>Exit from Service Mode.</b> 8.Press the POWER Button to turn the power off. 9. Press FF and EJECT keys simultaneously in 6 times.	 (Normal Indication)

Fig.S1 Service Screen (sample)

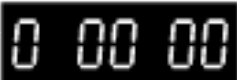
Service

MAIN VXKJ0.07 \* \*

Time ref. pos. NONE

Last error code 00

Model Code 81 (51h)

Option Code 1 8 (08h)

Option Code 2 212 (D4h)

Option Code 3 6 (06h)

Clock adjust + 0

VPS/PDC default OFF (depend)

Model No.	Model Code	Option Code 1	Option Code 2	Option Code 3
NV-FJ730EG	97 (61h)	8 (8h)	244 (F4h)	6 (6h)
NV-FJ730B	99 (63h)	40 (28h)	244 (F4h)	5 (5h)
NV-FJ730EC	98 (62h)	8 (8h)	244 (F4h)	6 (6h)
NV-FJ732EE	102 (66h)	8 (8h)	244 (F4h)	6 (6h)

Fig. S2 Model Code & Option Code

**NOTE:**

Since all electrical adjustments data is still not available, perform the Electrical Adjustment continuously.

[TOP](#) [PREVIOUS](#) [NEXT](#)

## 2.4 SELF-DIAGNOSIS RESULT DISPLAY

[TOP](#) [PREVIOUS](#) [NEXT](#)

The "SELF-DIAGNOSIS RESULT DISPLAY & MEMORY function is built in this VTR.

It means that when the VCR detects undesirable condition, it can be displayed a "Error code (Two numbers from the right)" with Service Mode 2.

Since the "Error code" is stored in the EEPROM, it can be displayed although after disconnected the AC leads. It can be displayed with Service Mode 2.

(If a second error had been detected, only the most recent error is displayed. )

For more details, refer to the Service Manual for Z-Mechanism Chassis Order number VRD9802005C2.

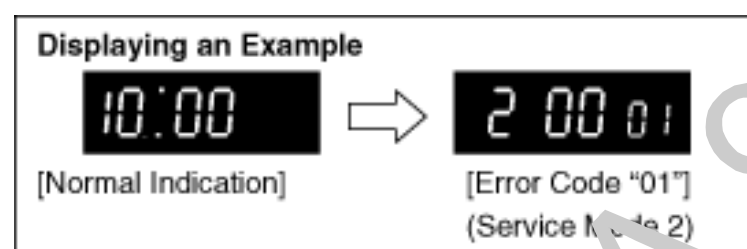

INDICATION	CAUSE	REMEDY/CHECK
01	After cylinder lock is detected, the cylinder does not start rotating again even after tape unloading.	Check the cylinder motor drive circuit.
02	Cassette tape is not wound up during the tape unloading except EJECT mode.	Check the capstan motor drive circuit.
03	Mechanism locks during mode transition except EJECT mode.	<ol style="list-style-type: none"> <li>1. Check the loading motor drive circuit.</li> <li>2. Check the mechanism phase alignment.</li> <li>3. Check the mode switch.</li> </ol>
04	Mechanism locks during tape unloading.	<ol style="list-style-type: none"> <li>1. Check the loading motor drive circuit.</li> <li>2. Check the mechanism phase alignment.</li> </ol>
06	Mechanism locks after tape unloading in EJECT mode.	<ol style="list-style-type: none"> <li>1. Check the loading motor drive circuit.</li> <li>2. Check the mechanism phase alignment for cassette holder unit.</li> </ol>
07	During recording mode, recording signal is less than the normal condition.	Protection of the over-current flowing in transistor which produces the power supply for recording mode.
08	Recording circuit works except recording mode.	Check the recording circuit.
16	Cylinder lock detection.	Check the cylinder unit and the cylinder motor drive circuit.
17	Supply reel mechanism lock detection	Check the supply reel mechanism and the supply reel circuit.
18	Take-up reel mechanism lock detection	Check the Take-up reel mechanism and the Take-up reel circuit.
2*	PG shifter automatic adjustment error.	Check the servo/system control circuit and the cylinder unit.

Fig. T1 Self-Test indication Display

[TOP](#) [PREVIOUS](#) [NEXT](#)

### 3.3.4 PG SHIFTER ADJUSTMENT/ (AUTOMATIC)

[TOP](#) [PREVIOUS](#) [NEXT](#)





PROCEDURES	FIP DISPLAY
Press the FF and EJECT Keys simultaneously for 3 seconds.	
Press the FF and EJECT Keys simultaneously twice.	
Press the EJECT key for 3 seconds.	
Press the CH UP key once.	
Insert the Alignment cassette tape. (PAL:VFJ8125H3F)	
When the sequence of the automatical adjustment has been terminated, the following action has been made. *SUCCEED: The cassette tape is ejected. *ERROR : The "F2" is displayed on the FIP. (Check the Servo/Syscon circuit and Cylinder unit.)	
Release the Service mode by pressing the EJECT and FF keys simultaneously in 6 times until the FIP becomes normal indication.	

Fig. E3

[TOP](#) [PREVIOUS](#) [NEXT](#)

## 3.3.5 AI FUNCTION ADJUSTMENT (AUTOMATIC)

[TOP](#) [PREVIOUS](#) [NEXT](#)





PROCEDURES	FIP DISPLAY
Press the FF and EJECT Keys simultaneously for 3 seconds.	
Press the FF and EJECT Keys simultaneously twice.	
Press the EJECT key for 3 seconds.	
Press the CH UP key in 3 times.	
Insert the blank cassette tape. (The adjustment is automatically started.)	
When the sequence of the automatic adjustment has been terminated successfully, the VCR goes to STOP mode.	
Release the Service mode by pressing the EJECT and FF keys simultaneously in 6 times until the FIP becomes normal indication.	

Fig. E4

[TOP](#) [PREVIOUS](#) [NEXT](#)



# SYSTEM CONTROL & SERVO TRs DC VOLTAGE CHART (SP MODE)

Ref. No. MODE	Q1501			Q1502			Q7701			Q7702			Q7703		
	+	-		+	-		E	C	B	E	C	B	E	C	B
STOP	4.7	0.0		4.9	0.0		1.6	0.0	0.9	0.0	4.9	0.0	0.0	0.0	0.6
PLAY	4.7	0.0		4.9	0.0		1.6	0.0	0.9	0.0	4.9	0.0	0.0	0.0	0.6
REC	4.6	0.0		4.8	0.0		1.6	0.0	0.9	0.0	4.9	0.0	0.0	0.0	0.5
F.F	4.7	0.0		4.9	0.0		1.6	0.0	0.9	0.0	4.9	0.0	0.0	0.0	0.5
REW	4.9	0.0		4.9	0.0		1.6	0.0	0.9	0.0	4.9	0.0	0.0	0.0	0.5

Ref. No. MODE	Q7704			Q7707		
	E	C	B	E	C	B
STOP	0.0	4.2	0.0	2.5	0.0	1.9
PLAY	0.0	4.2	0.0	2.5	0.0	1.9
REC	0.0	4.2	0.0	2.5	0.0	1.9
F.F	0.0	4.2	0.0	2.5	0.0	1.9
REW	0.0	4.2	0.0	2.5	0.0	1.9

Ref. No. MODE	QR6001			QR6002			QR6006			QR6007		
	E	C	B	E	C	B	E	C	B	E	C	B
STOP	0.0	0.0	4.9	0.0	2.3	0.0	0.0	0.0	4.9	0.0	2.3	0.0
PLAY	0.0	12.3	0.0	0.0	0.0	0.0	0.0	0.0	4.8	0.0	0.0	0.0
REC	0.0	0.0	4.9	0.0	1.5	0.0	0.0	0.0	4.8	0.0	1.5	0.0
F.F	0.0	0.0	4.9	0.0	0.0	0.0	0.0	0.0	4.8	0.0	0.0	0.0
REW	0.0	0.0	4.9	0.0	0.0	0.0	0.0	0.0	4.8	0.0	0.0	0.0



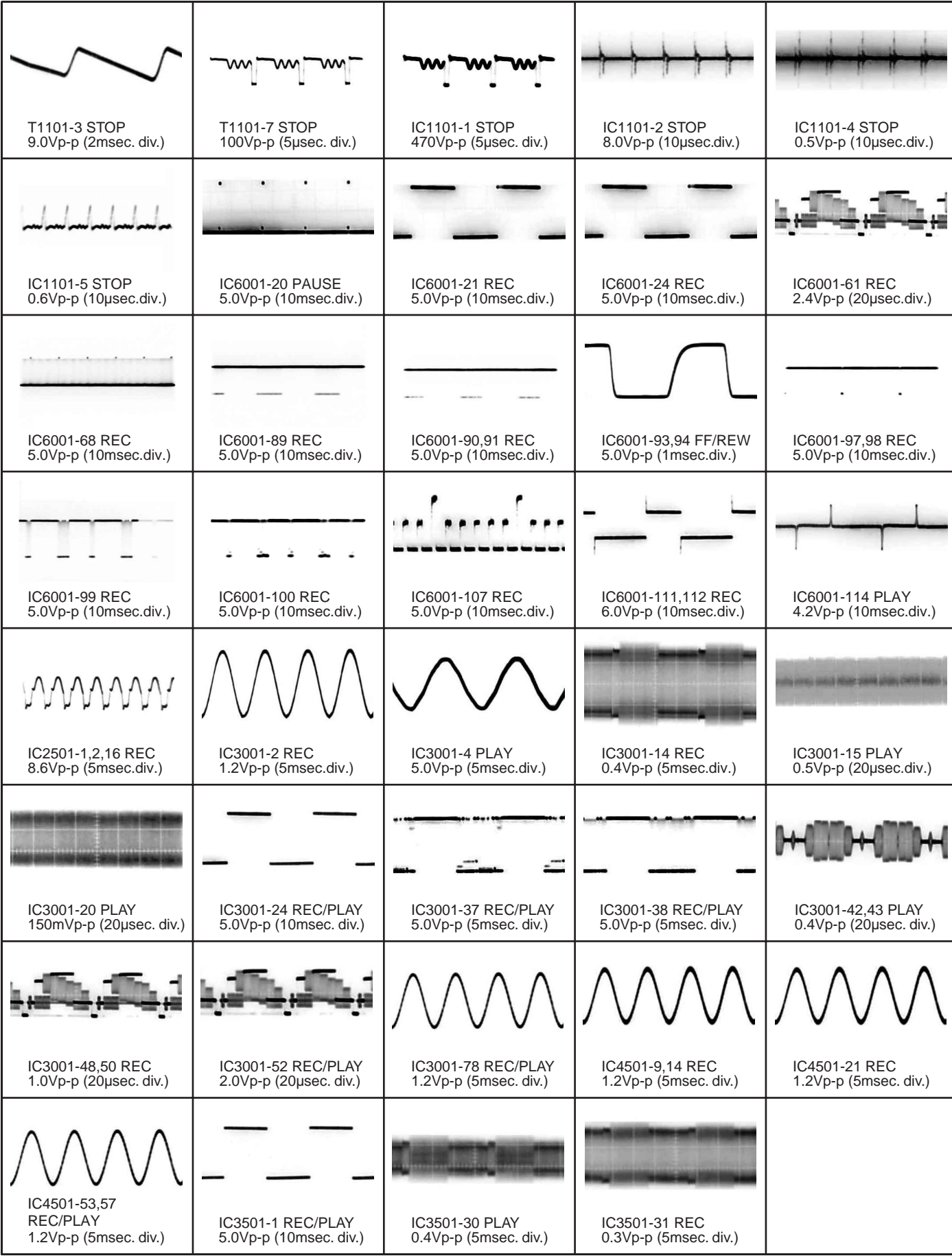

# 8 SCHEMATIC DIAGRAMS

## 8.1. POWER TRANSFORMER SECTION IN MAIN SCHEMATIC DIAGRAM

**CAUTION** THE STRIPED FRAME INDICATES THE PRIMARY CIRCUIT TO DISTINGUISH THE PRIMARY FROM THE SECONDARY CIRCUIT.  
 PAY ATTENTION NOT TO RECEIVE AN ELECTRIC SHOCK DURING REPAIR AND SERVICE OF THE PRODUCTS.

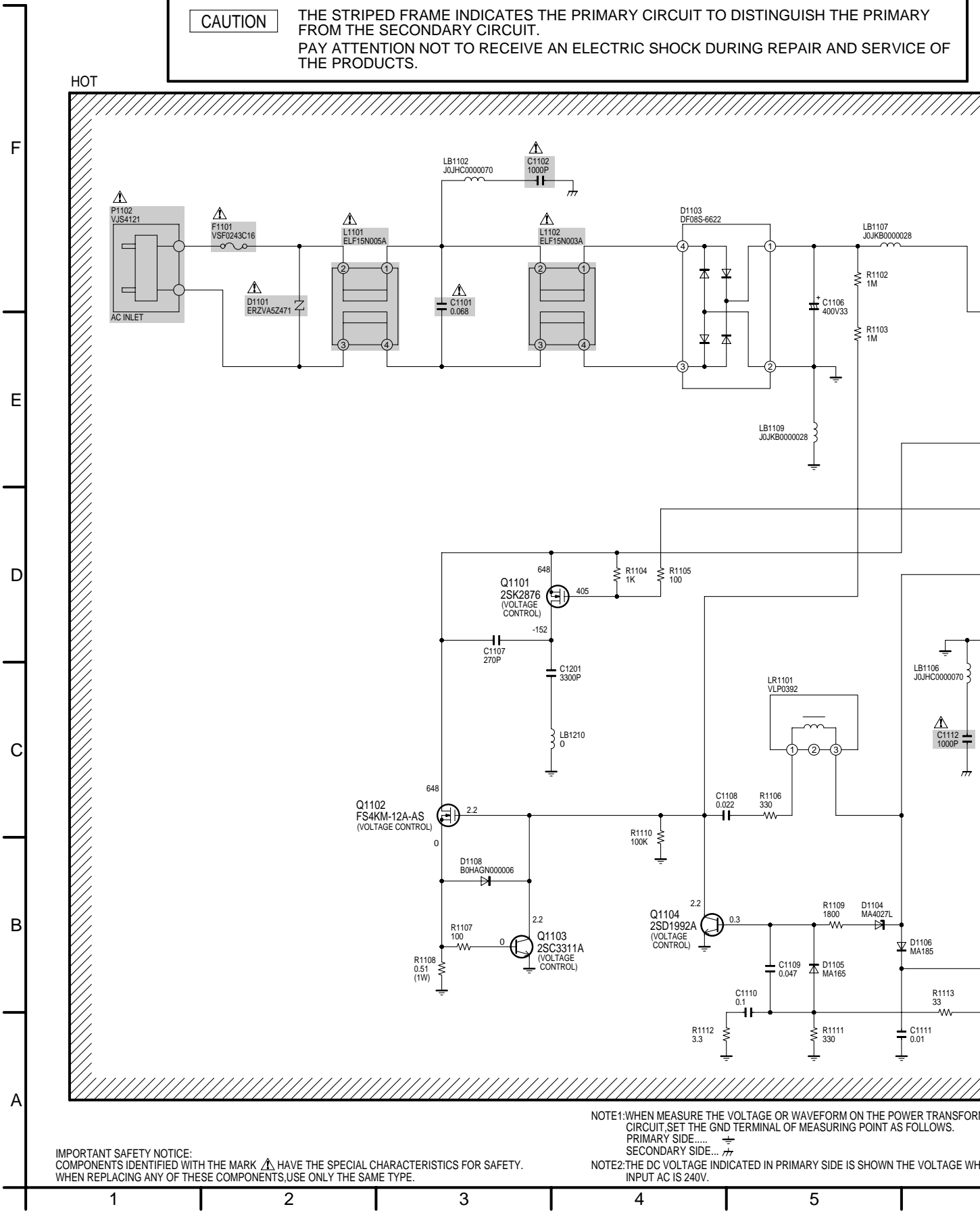

**IMPORTANT SAFETY NOTICE:**  
 COMPONENTS IDENTIFIED WITH THE MARK HAVE THE SPECIAL CHARACTERISTICS FOR SAFETY.  
 WHEN REPLACING ANY OF THESE COMPONENTS, USE ONLY THE SAME TYPE.

**NOTE1:** WHEN MEASURE THE VOLTAGE OR WAVEFORM ON THE POWER TRANSFORMER CIRCUIT, SET THE GND TERMINAL OF MEASURING POINT AS FOLLOWS.  
 PRIMARY SIDE.....   
 SECONDARY SIDE...

**NOTE2:** THE DC VOLTAGE INDICATED IN PRIMARY SIDE IS SHOWN THE VOLTAGE WHEN INPUT AC IS 240V.

PRIMARY  
SERVICE OF

- (R) :TO POWER SUPPLY/RF SECTION
- (S) :TO SYSTEM CONTROL & SERVO SECTION
- (T) :TO TIMER SECTION

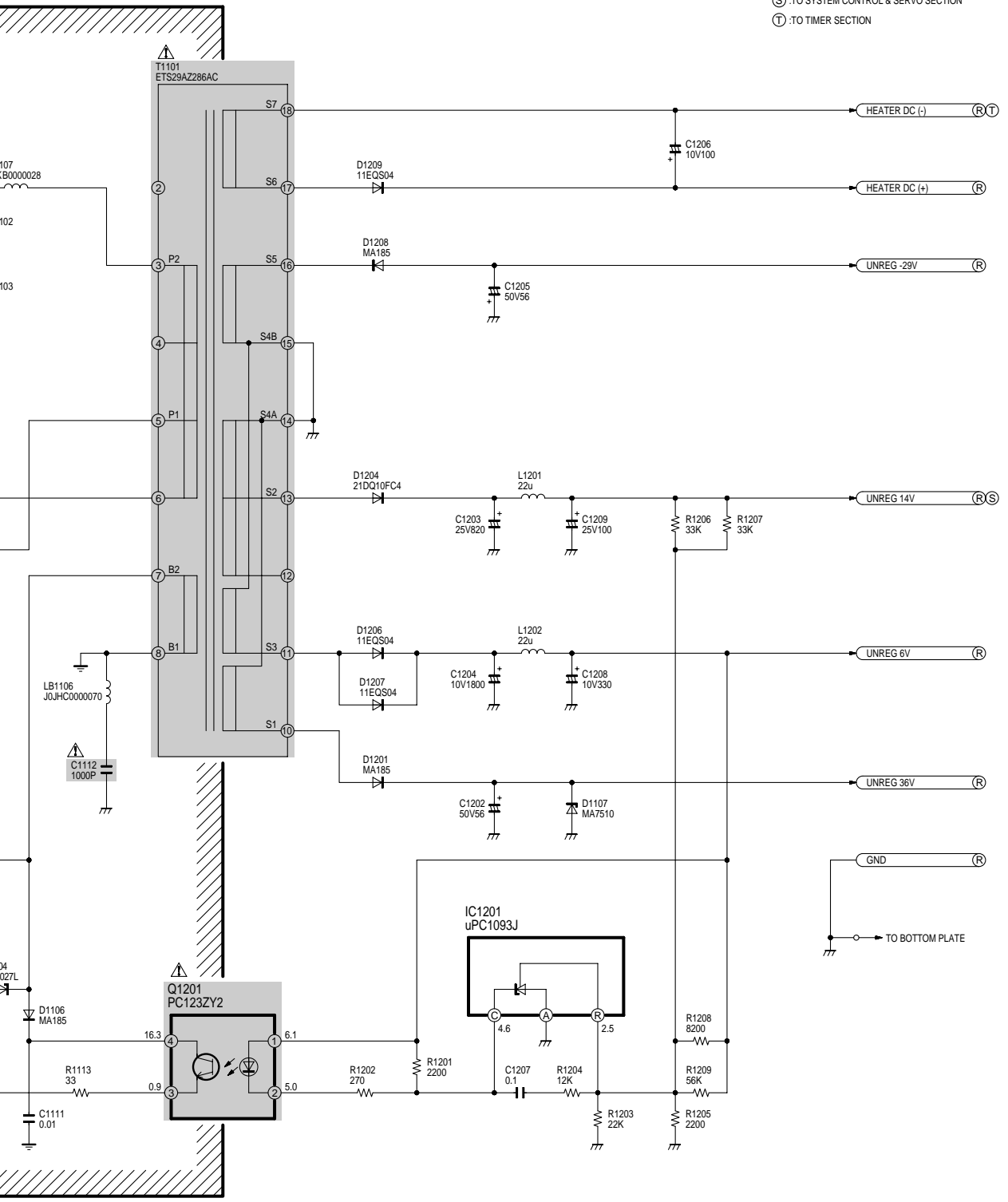

THE POWER TRANSFORMER  
WINDING CONNECTIONS ARE AS FOLLOWS.

NOTE:DO NOT USE ANY PART NUMBER SHOWN ON THIS SCHEMATIC DIAGRAM FOR  
ORDERING.WHEN YOU ORDER A PART,PLEASE REFER TO PARTS LIST.  
NOTE:THE MEASUREMENT MODE OF THE DC VOLTAGE ON THIS DIAGRAM IS STOP MODE.

NV-FJ730EG/B/EC,FJ732EE  
POWER TRANSFORMER  
SECTION SCHEMATIC DIAGRAM

6 7 8 9 10

## 8.2. POWER SUPPLY/ RF SECTION IN MAIN SCHEMATIC DIAGRAM

- (P) .TO POWER TRANSFORMER SECTION
- (S) .TO SYSTEM CONTROL & SERVO SECTION
- (V) .TO LUMINANCE & CHROMINANCE/AUDIO SECTION
- (A) .TO HI-FI AUDIO SECTION
- (I) .TO INPUT/OUTPUT SECTION
- (T) .TO TIMER SECTION

VIDEO MAIN SIGNAL PATH IN REC MODE  
 VIDEO MAIN SIGNAL PATH IN PLAYBACK MODE

AUDIO MAIN SIGNAL PATH IN REC MODE  
 AUDIO MAIN SIGNAL PATH IN PLAYBACK MODE

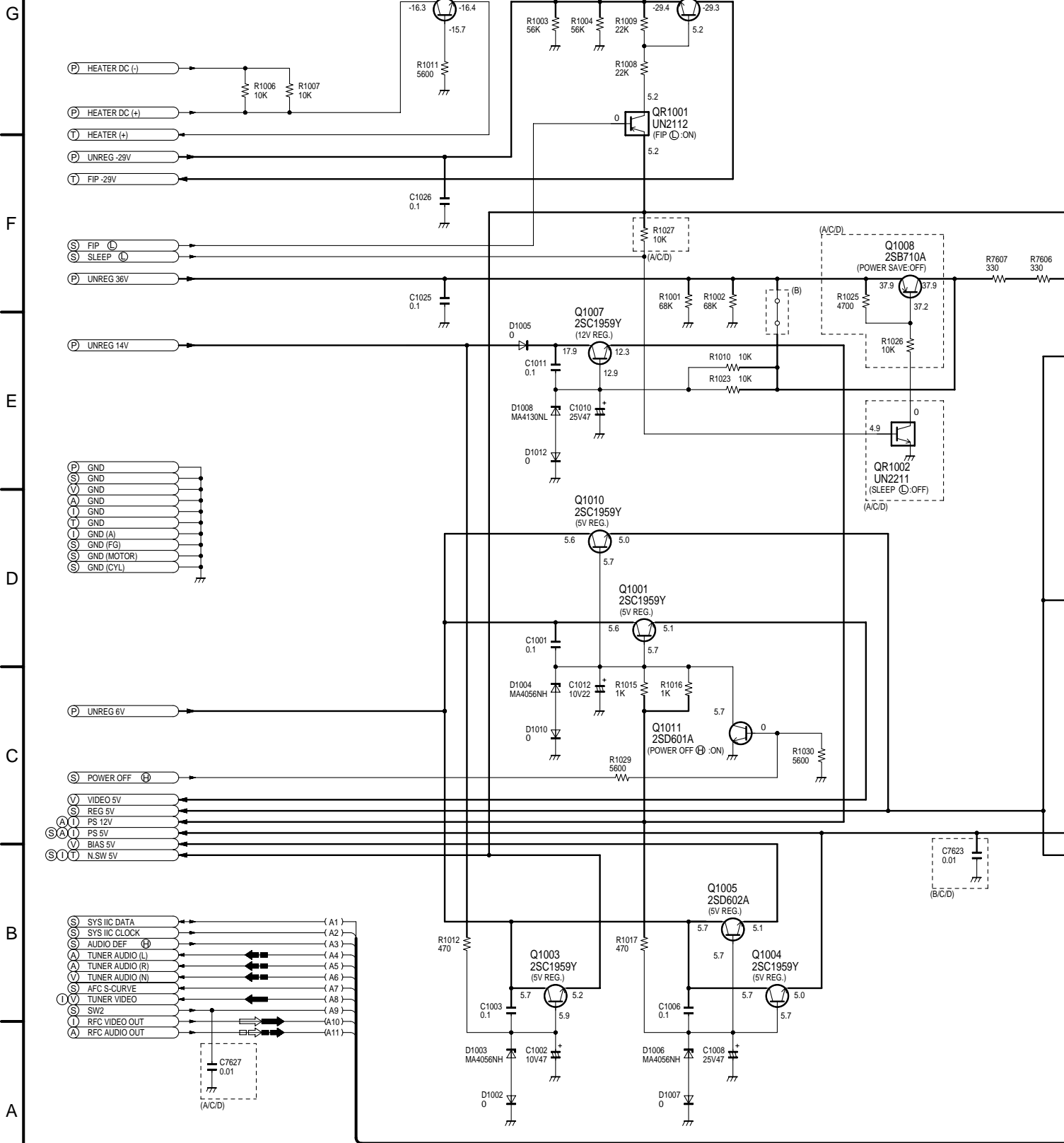

IMPORTANT SAFETY NOTICE:  
COMPONENTS IDENTIFIED WITH THE MARK HAVE THE SPECIAL CHARACTERISTICS FOR SAFETY.  
WHEN REPLACING ANY OF THESE COMPONENTS, USE ONLY THE SAME TYPE.

NOTE: THE MEASUREMENT MODE OF THE DC VOLTAGE ON THIS DIAGRAM IS STOP MODE.

1 | 2 | 3 | 4 | 5 | 6

ATH IN REC MODE  
 ATH IN PLAYBACK MODE

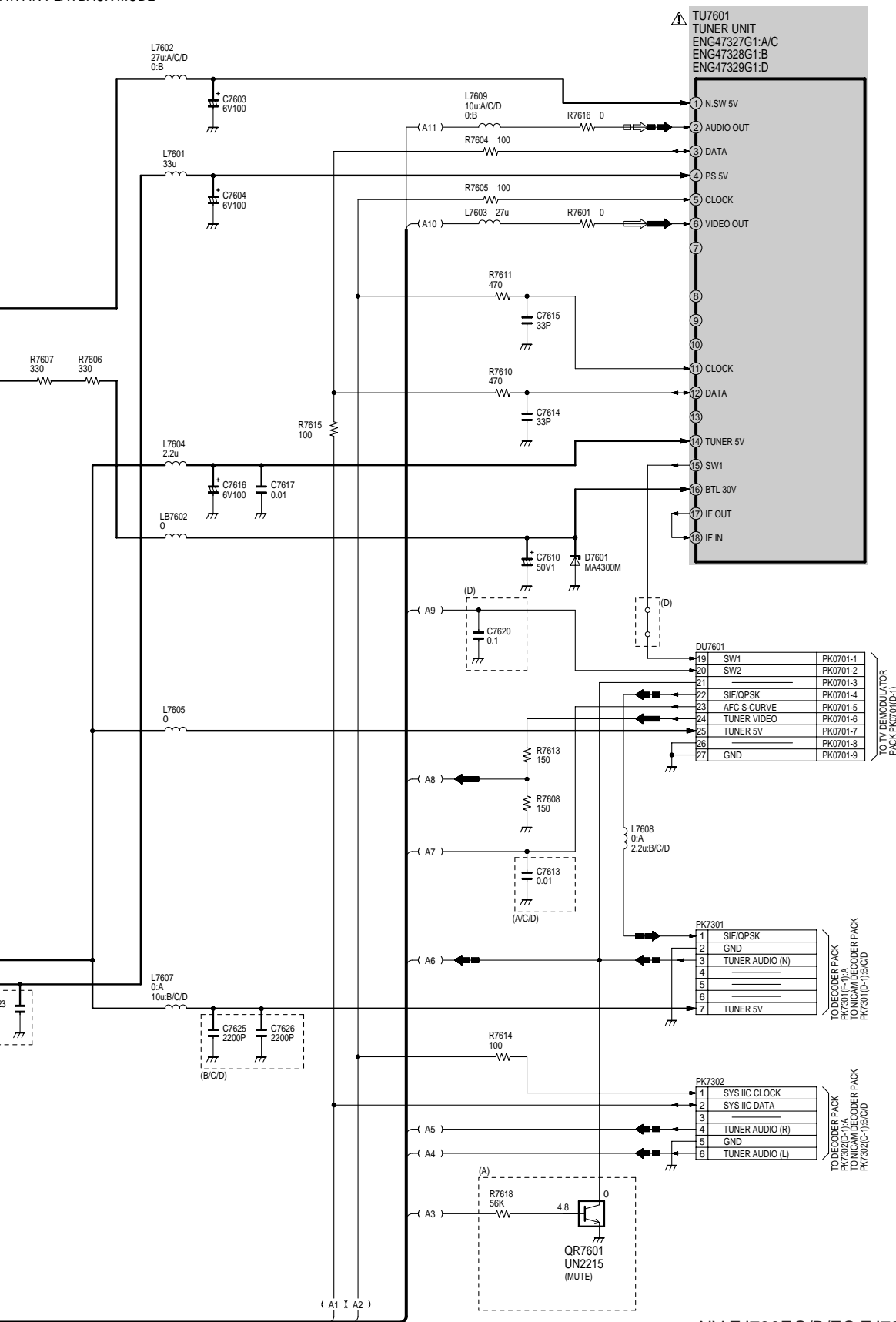

NOTE: DO NOT USE ANY PART NUMBER SHOWN ON THIS SCHEMATIC DIAGRAM FOR ORDERING. WHEN YOU ORDER A PART, PLEASE REFER TO PARTS LIST.

NV-FJ730EG/B/EC, FJ732EE  
 POWER SUPPLY/RF SECTION  
 SCHEMATIC DIAGRAM

TOP MODE.

6

7

8

9

10

### 8.3. TIMER SECTION IN MAIN SCHEMATIC DIAGRAM

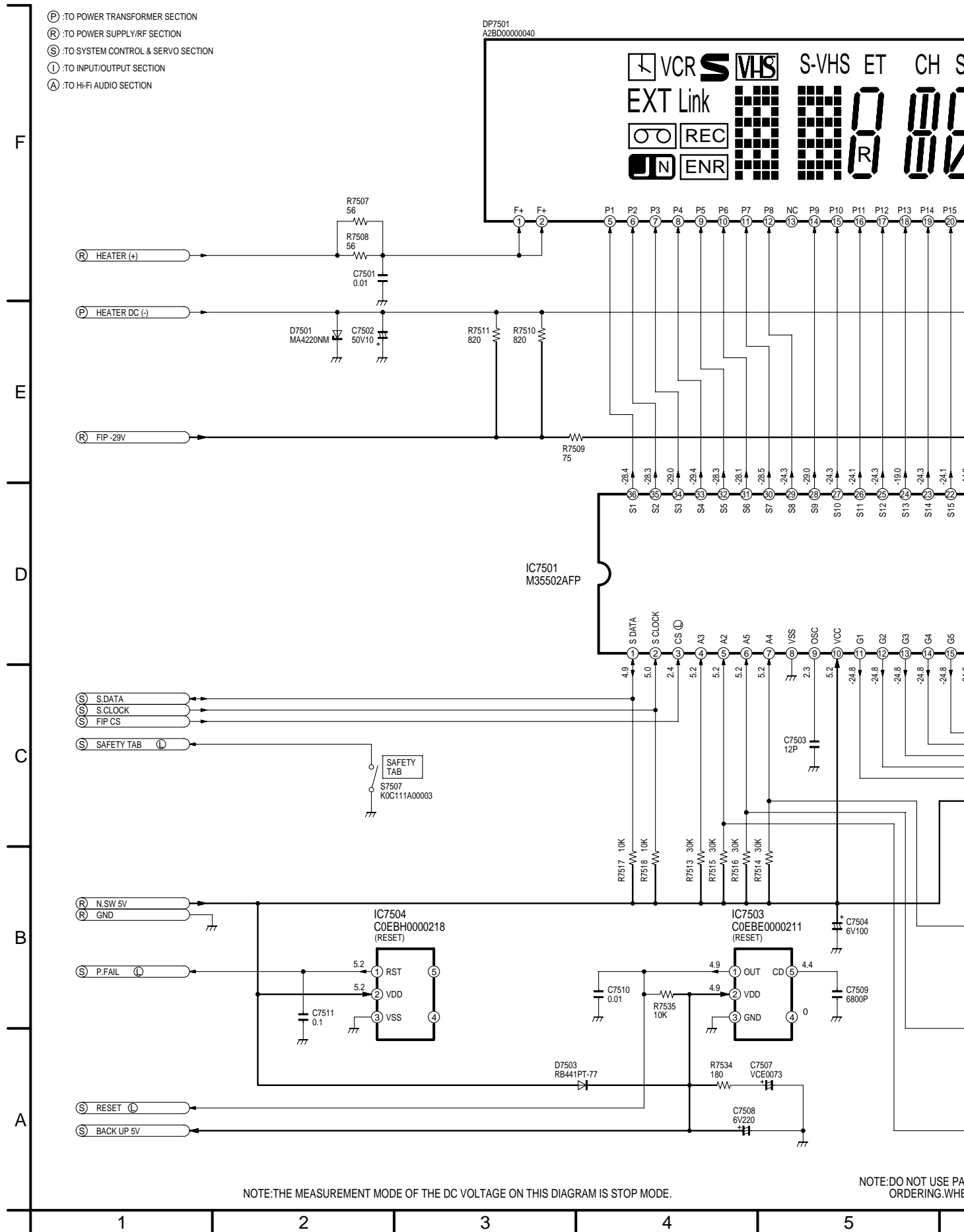

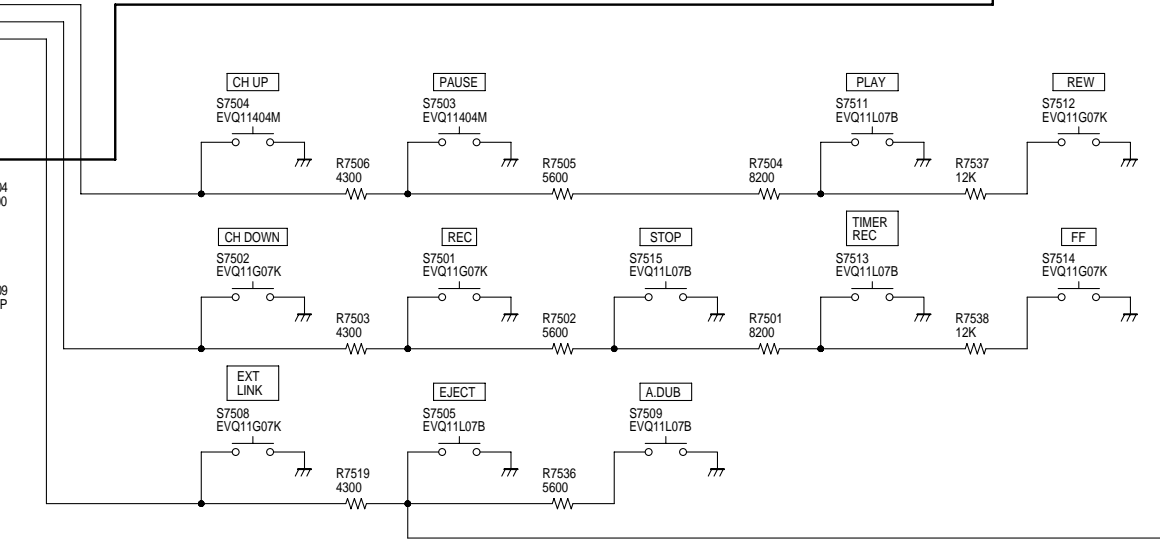
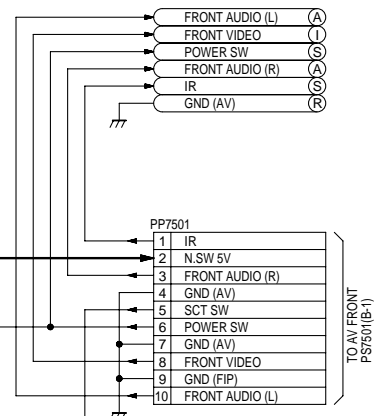
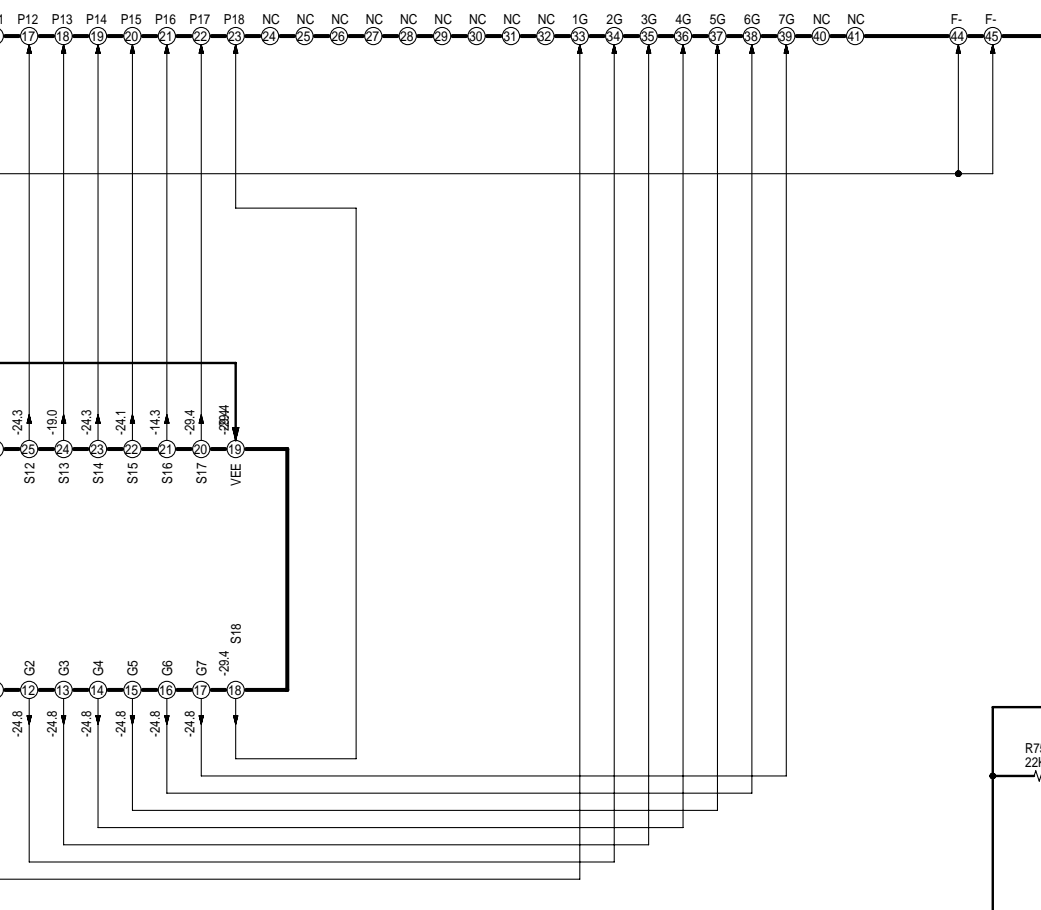
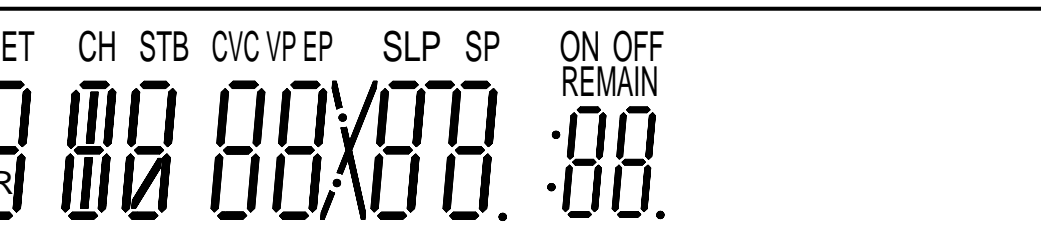

NOTE: DO NOT USE PART NUMBER SHOWN ON THIS SCHEMATIC DIAGRAM FOR ORDERING. WHEN YOU ORDER A PART, PLEASE REFER TO PARTS LIST.

NV-FJ730EG/B/EC, FJ732EE  
 TIMER SECTION SCHEMATIC DIAGRAM

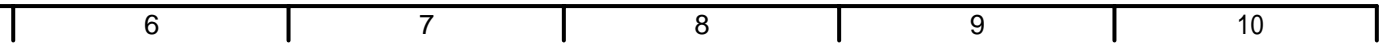

# 8.4. SYSTEM CONTROL & SERVO SECTION IN MAIN SCHEMATIC DIAGRAM

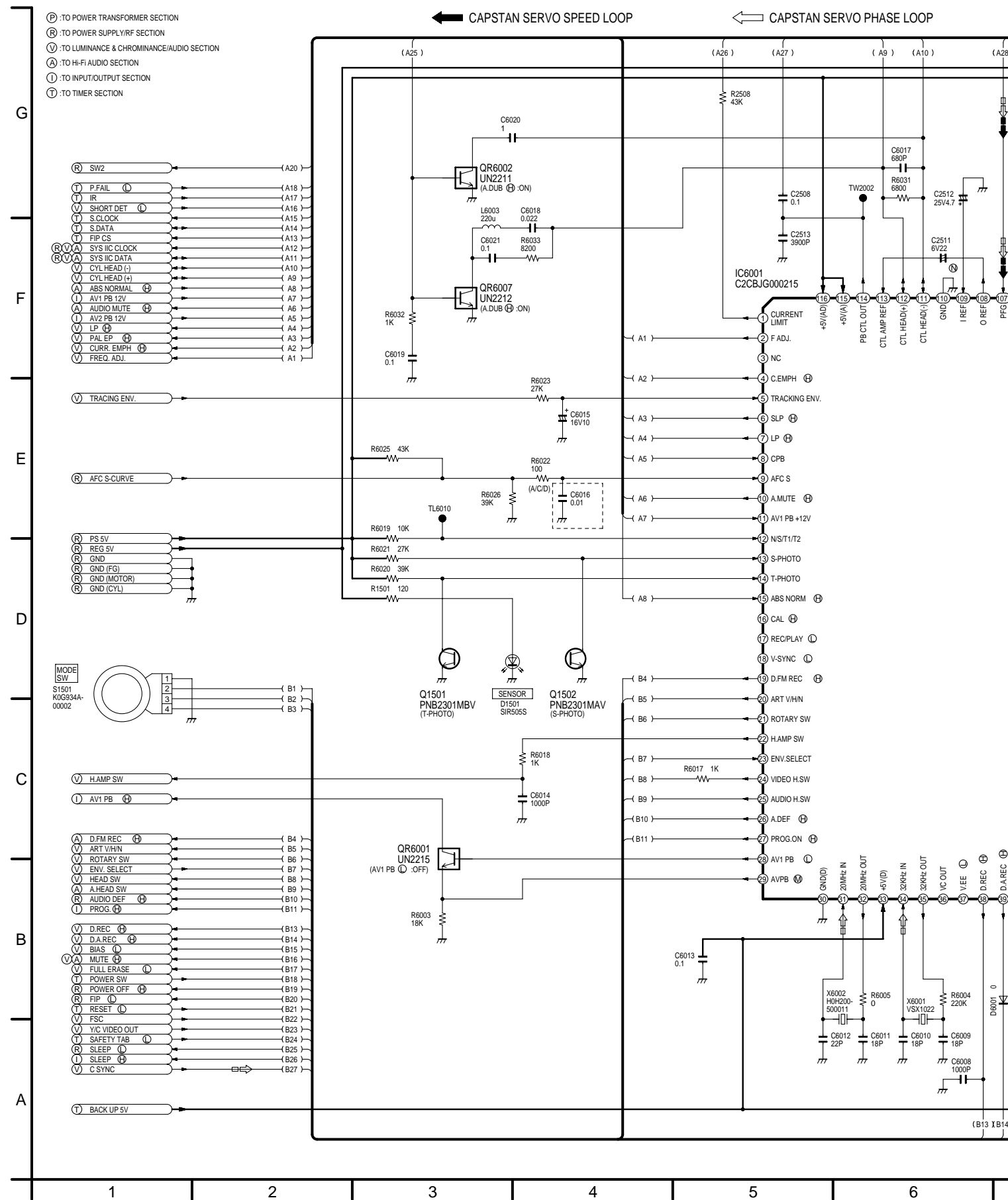



← CYLINDER SERVO SPEED LOOP

⇐ CYLINDER SERVO PHASE LOOP

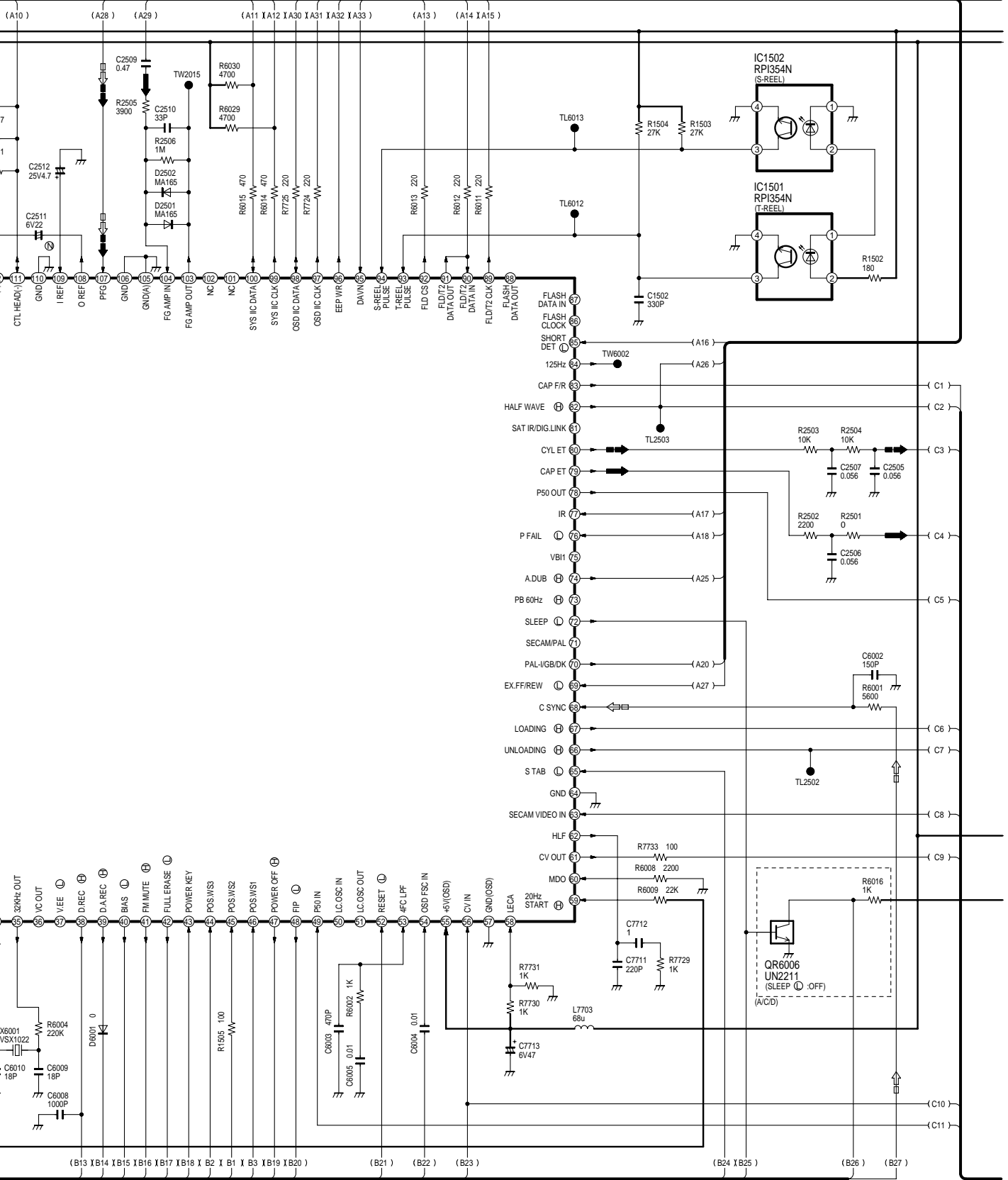

NV-FJ730EG/B/EC, FJ732EE SYSTEM CONTROL & SERVO SECTION SCHEMATIC DIAGRAM

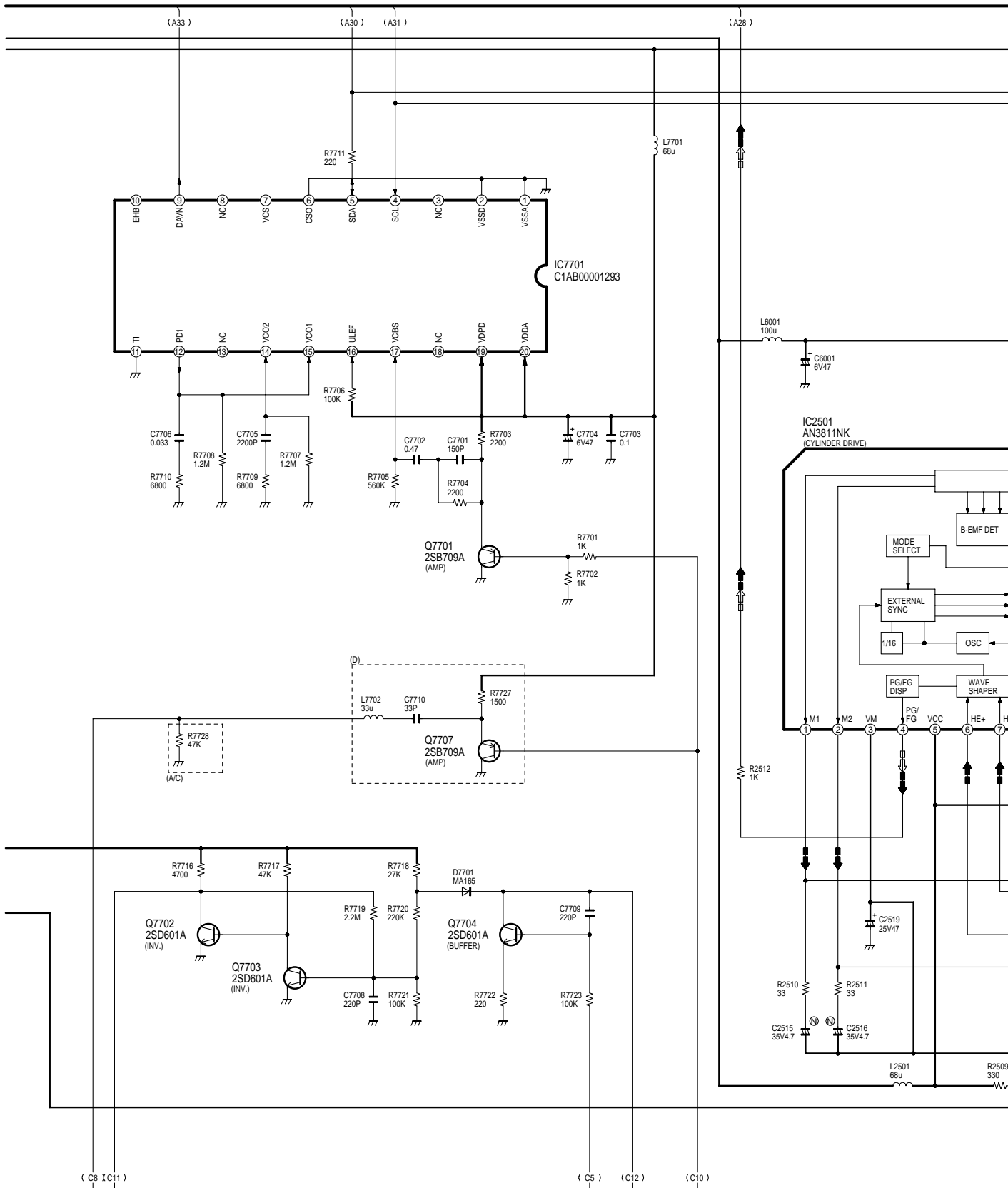

NV-FJ730EG/B/EC,FJ732EE  
SYSTEM CONTROL & SERVO SECTION SCHEMATIC DIAGRAM

NOTE: DO NOT USE ANY PART NUMBER SHOWN ON THIS SCHEMATIC DIAGRAM FOR ORDERING. WHEN YOU ORDER A PART, PLEASE REFER TO PARTS LIST.

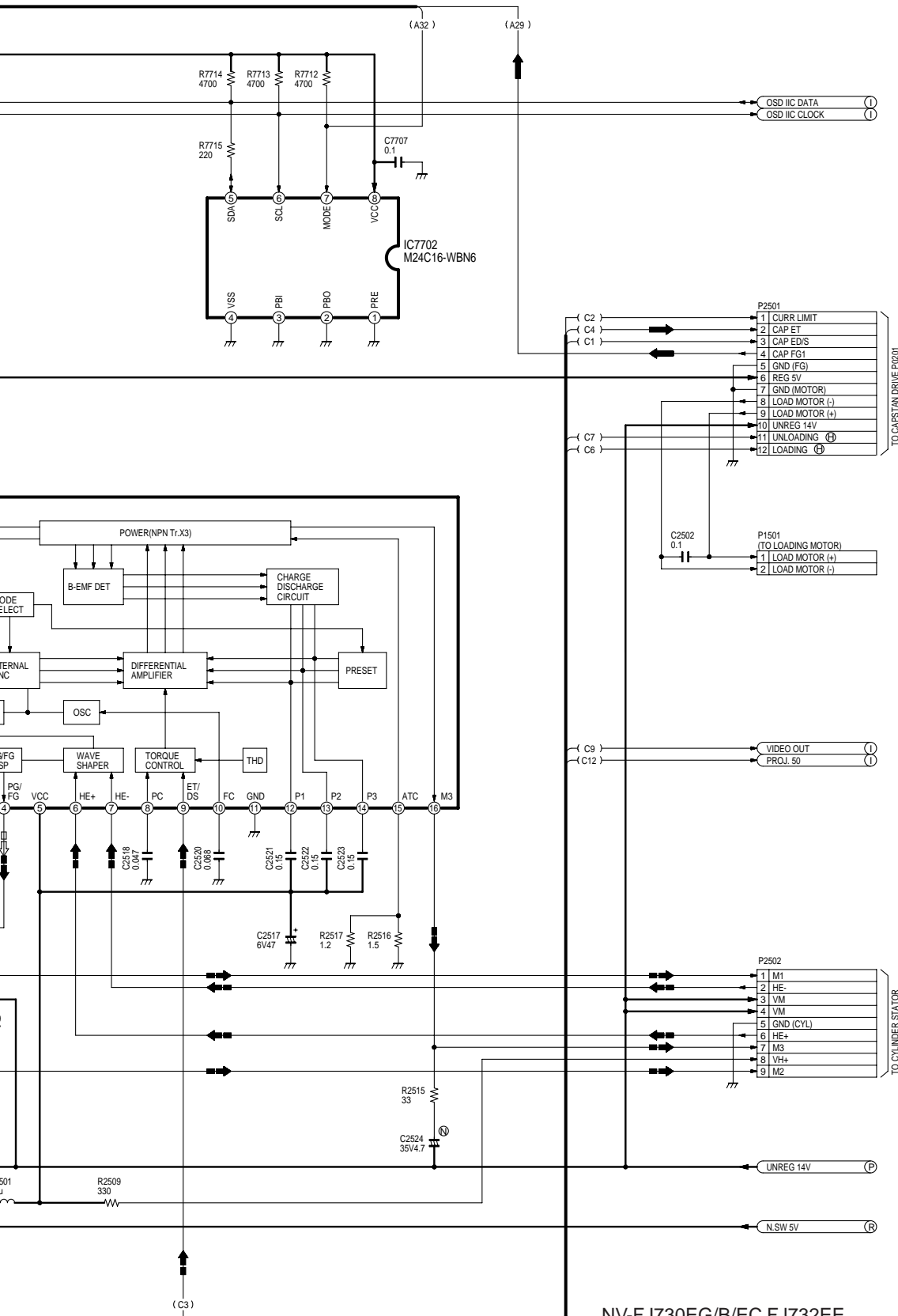

SCHEMATIC DIAGRAM FOR  
FOR PARTS LIST.

NV-FJ730EG/B/EC,FJ732EE  
SYSTEM CONTROL & SERVO  
SECTION SCHEMATIC DIAGRAM

# 8.5. LUMINANCE & CHROMINANCE/ AUDIO SECTION IN MAIN SCHEMATIC DIAGR.

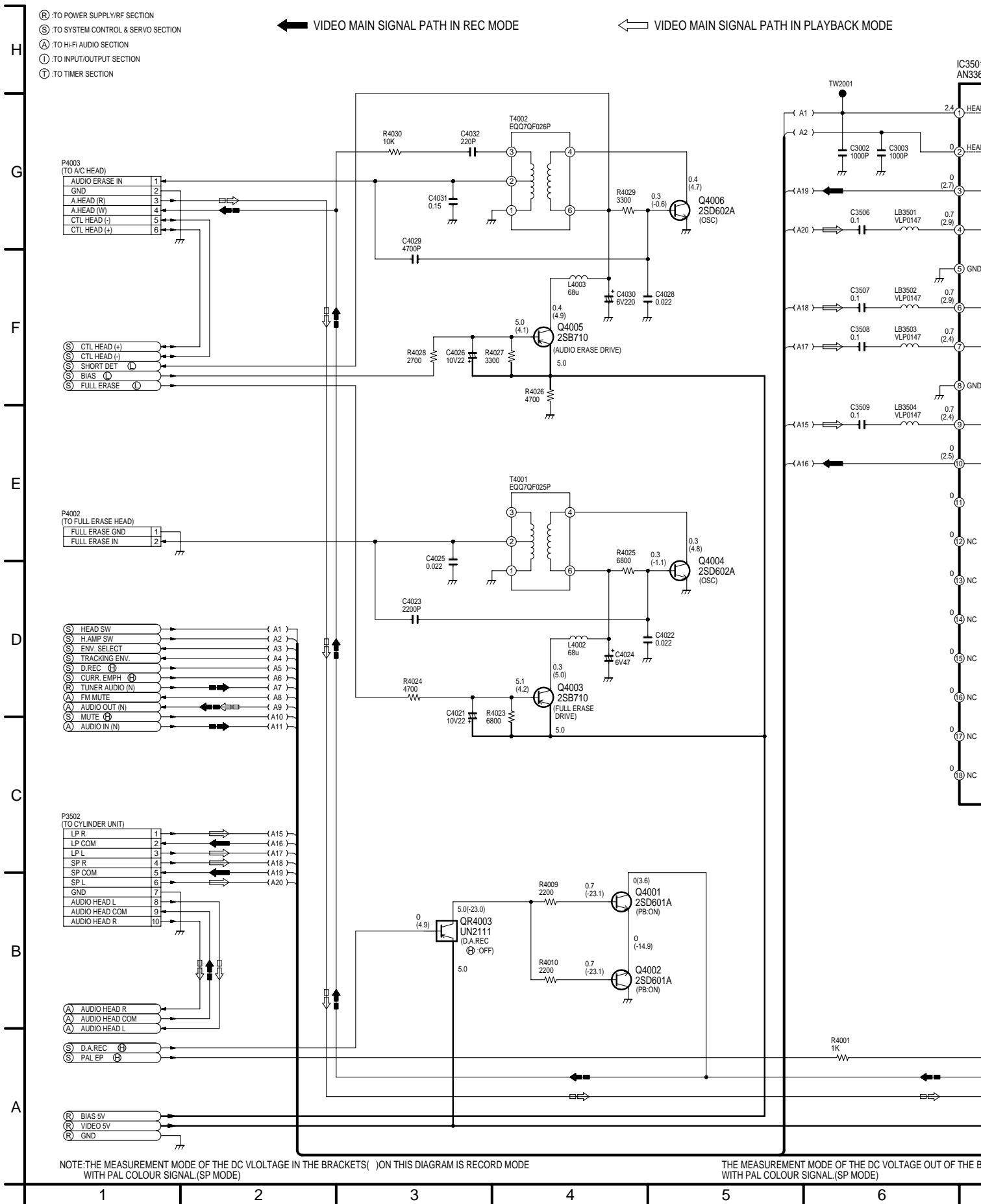

# C DIAGRAM

← AUDIO MAIN SIGNAL PATH IN REC MODE

⇨ AUDIO MAIN SIGNAL PATH IN PLAYBACK MODE

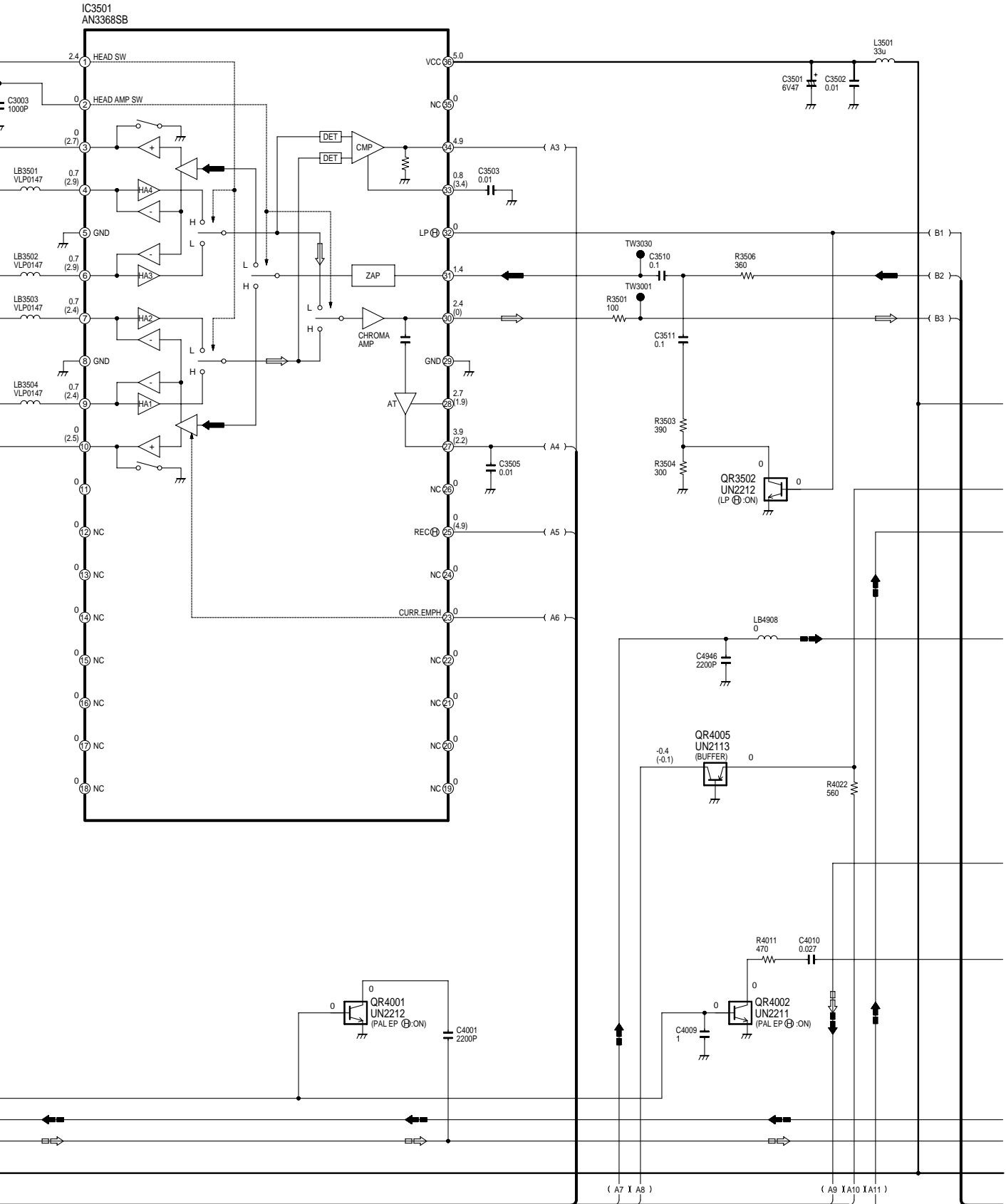

VOLTAGE OUT OF THE BRACKETS ON THIS DIAGRAM IS PLAYBACK MODE

NV-FJ730EG/B/EC, FJ732EE  
LUMINANCE & CHROMINANCE/AUDIO SECTION SCHEMATIC DIAGRAM

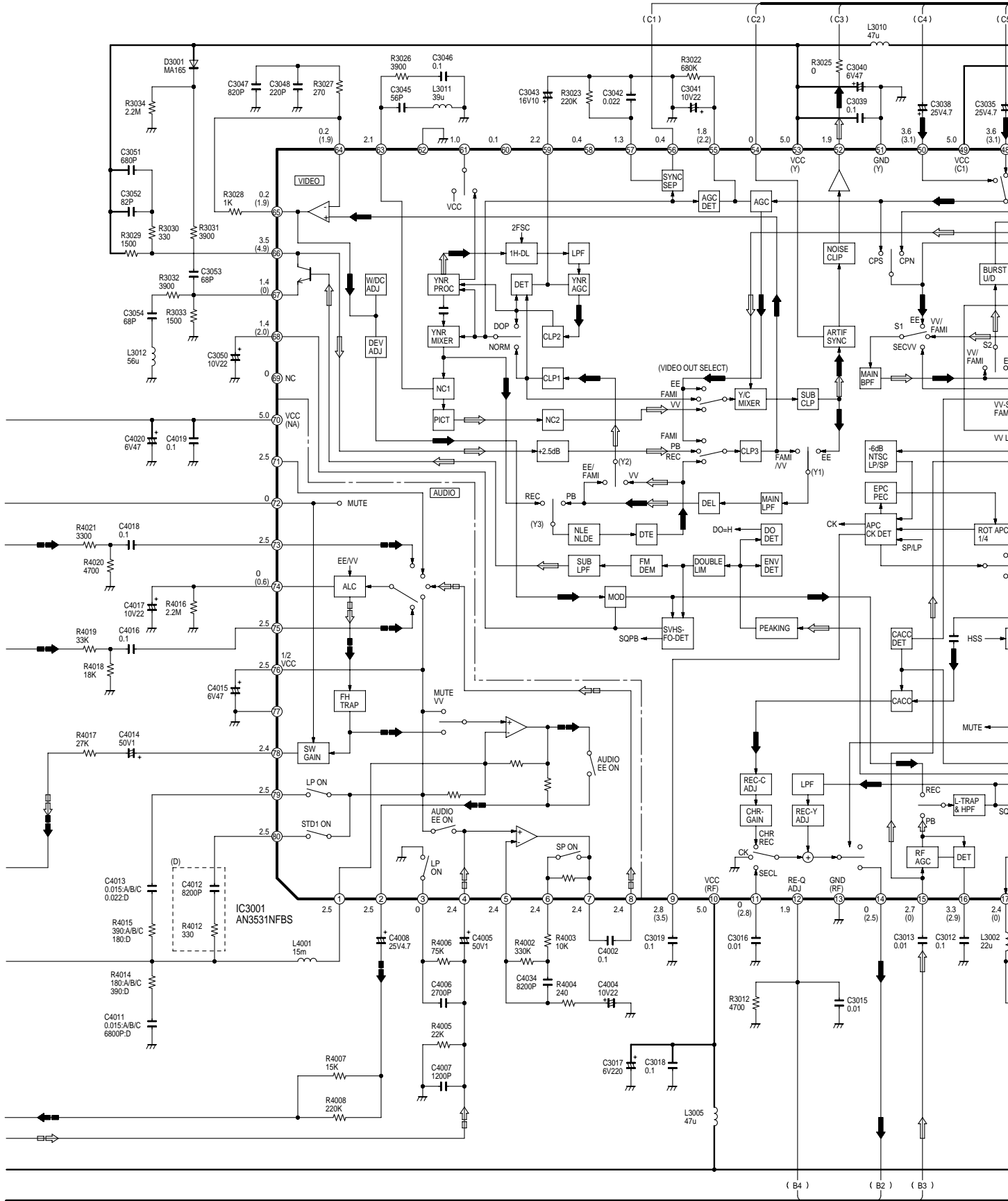

NV-FJ730EG/B/EC, FJ732EE  
LUMINANCE & CHROMINANCE/AUDIO SECTION SCHEMATIC DIAGRAM

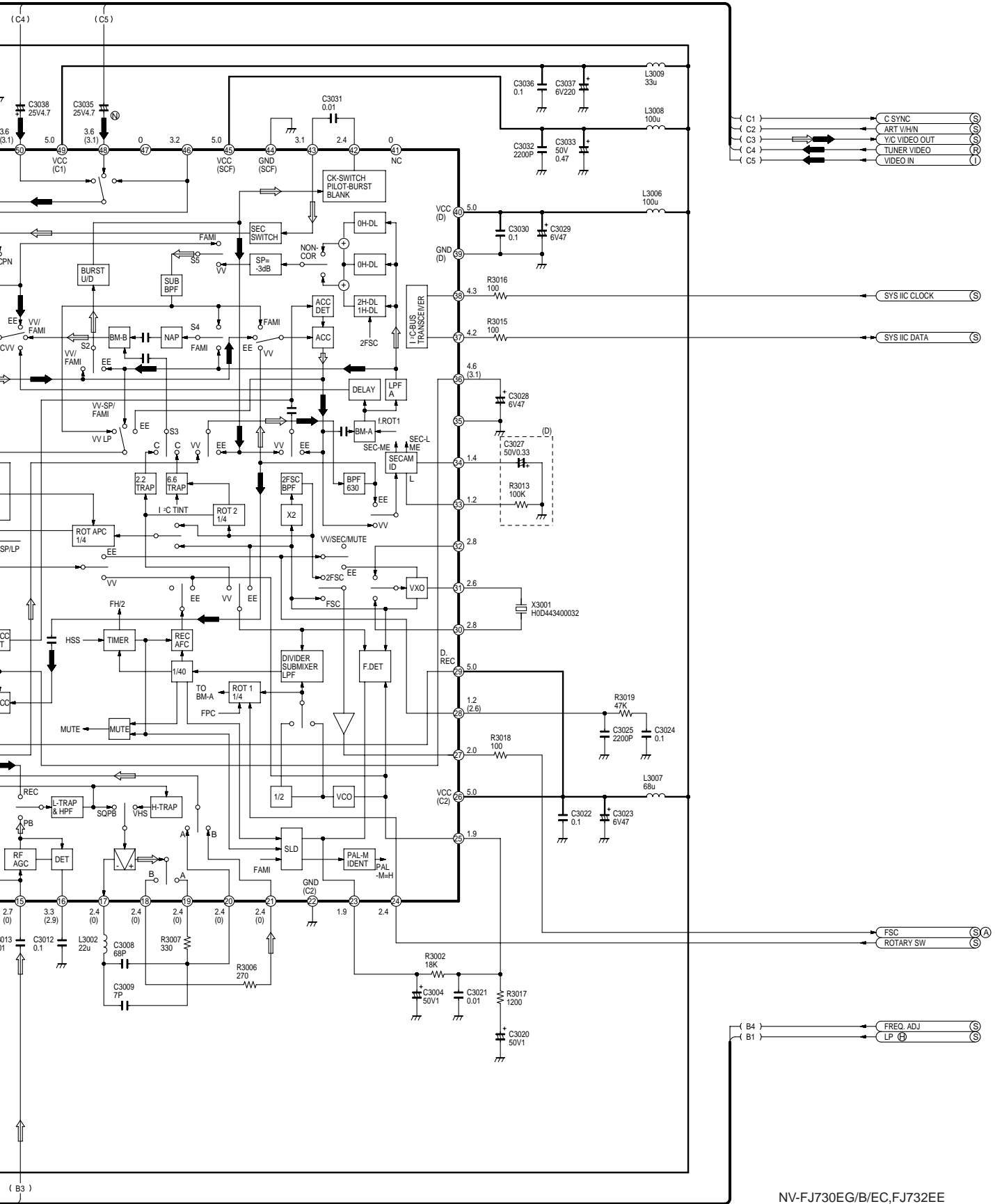

NOTE: DO NOT USE ANY PART NUMBER ON THIS SCHEMATIC DIAGRAM FOR ORDERING. WHEN YOU ORDER A PART, PLEASE REFER TO PARTS LIST.

NV-FJ730EG/B/EC, FJ732EE  
LUMINANCE & CHROMINANCE/AUDIO  
SECTION SCHEMATIC DIAGRAM

18 19 20 21 22 23

# 8.6. Hi-Fi AUDIO SECTION IN MAIN SCHEMATIC DIAGRAM

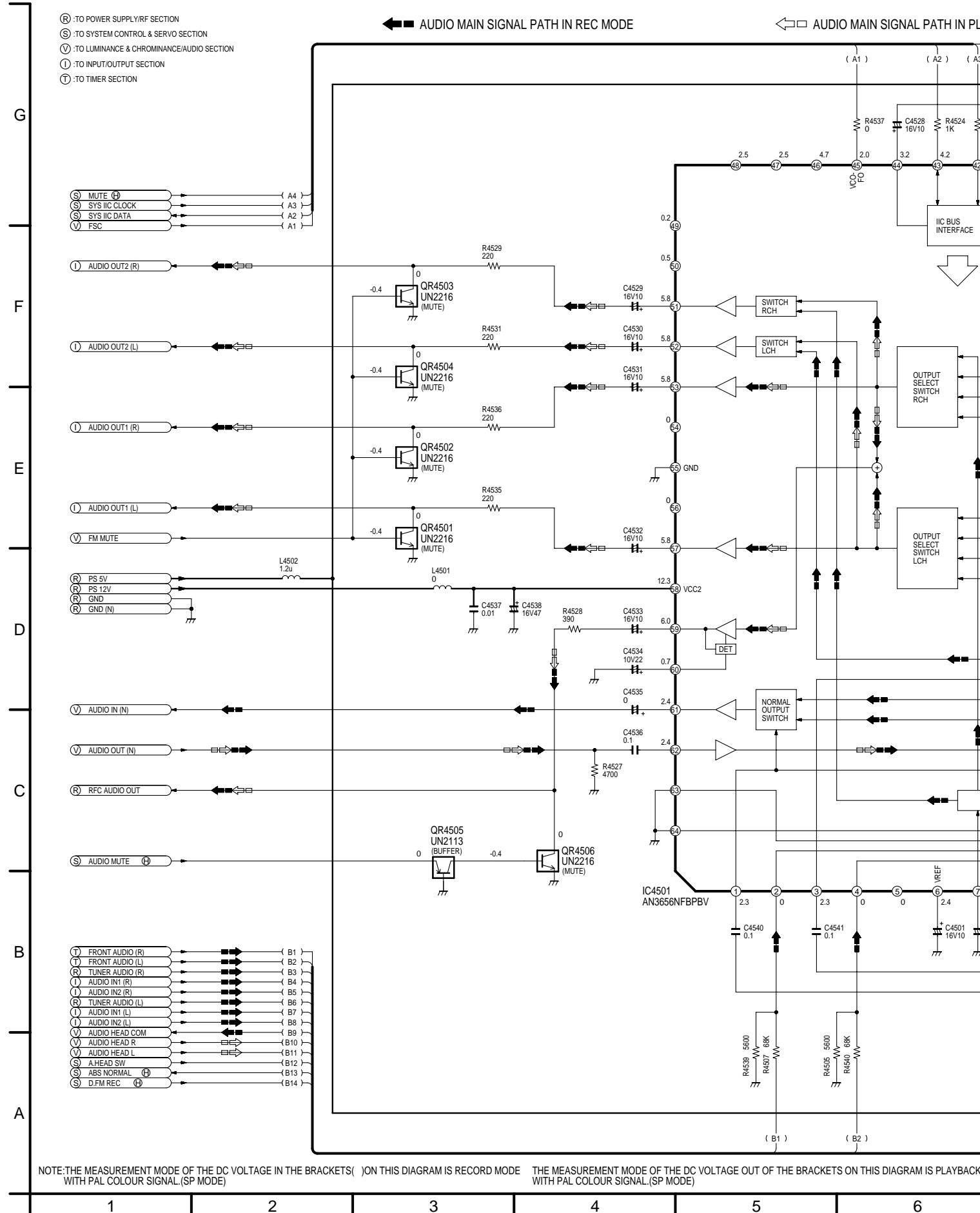



SIGNAL PATH IN PLAYBACK MODE

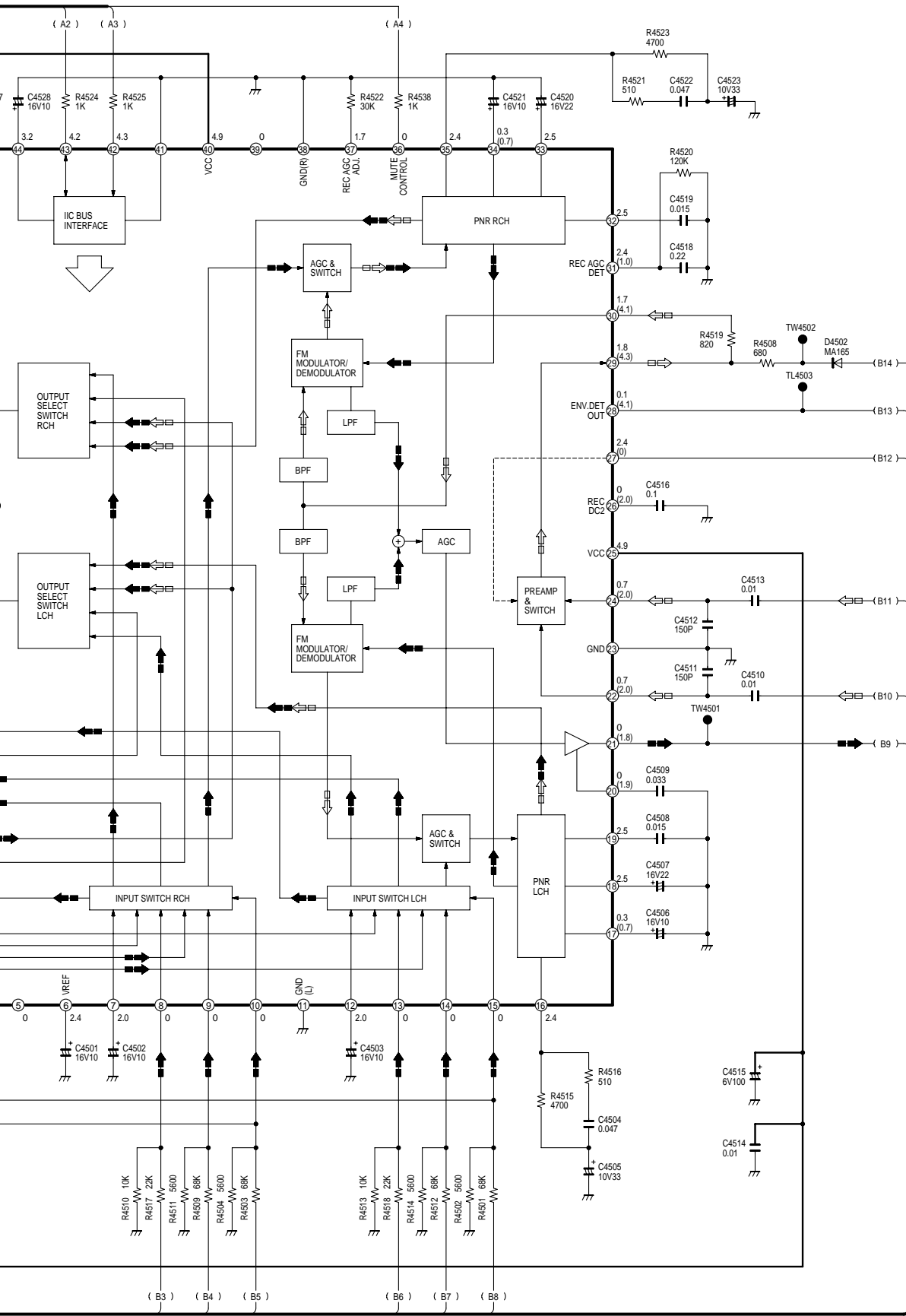
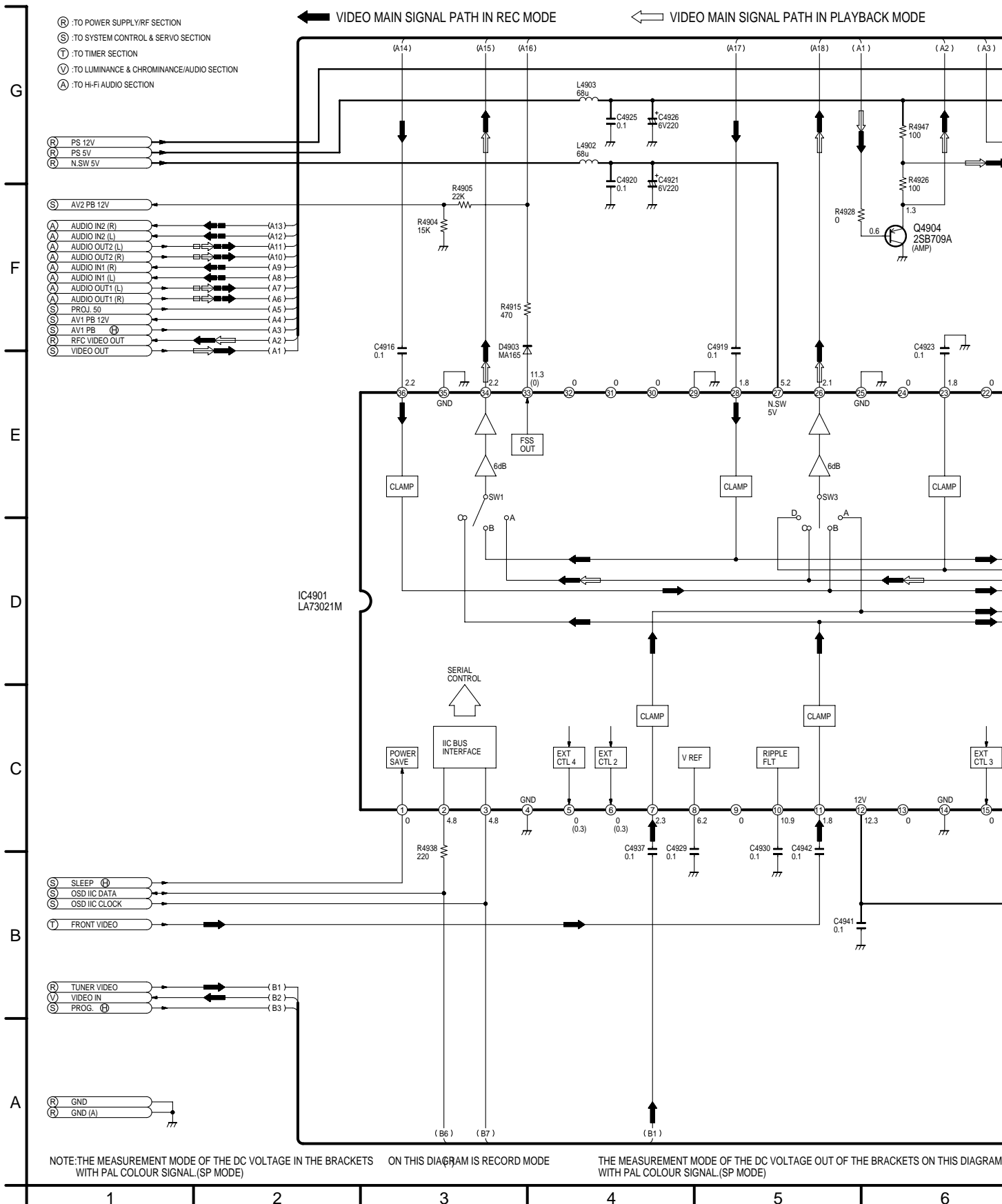

DIAGRAM IS PLAYBACK MODE

NOTE: DO NOT USE ANY PART NUMBER SHOWN ON THIS SCHEMATIC DIAGRAM FOR ORDERING. WHEN YOU ORDER A PART, PLEASE REFER TO PARTS LIST.

NV-FJ730EG/B/EC, FJ732EE  
Hi-Fi AUDIO SECTION SCHEMATIC DIAGRAM

# 8.7. INPUT/ OUTPUT SECTION IN MAIN SCHEMATIC DIAGRAM



← AUDIO MAIN SIGNAL PATH IN REC MODE

⇐ AUDIO MAIN SIGNAL PATH IN PLAYBACK MODE

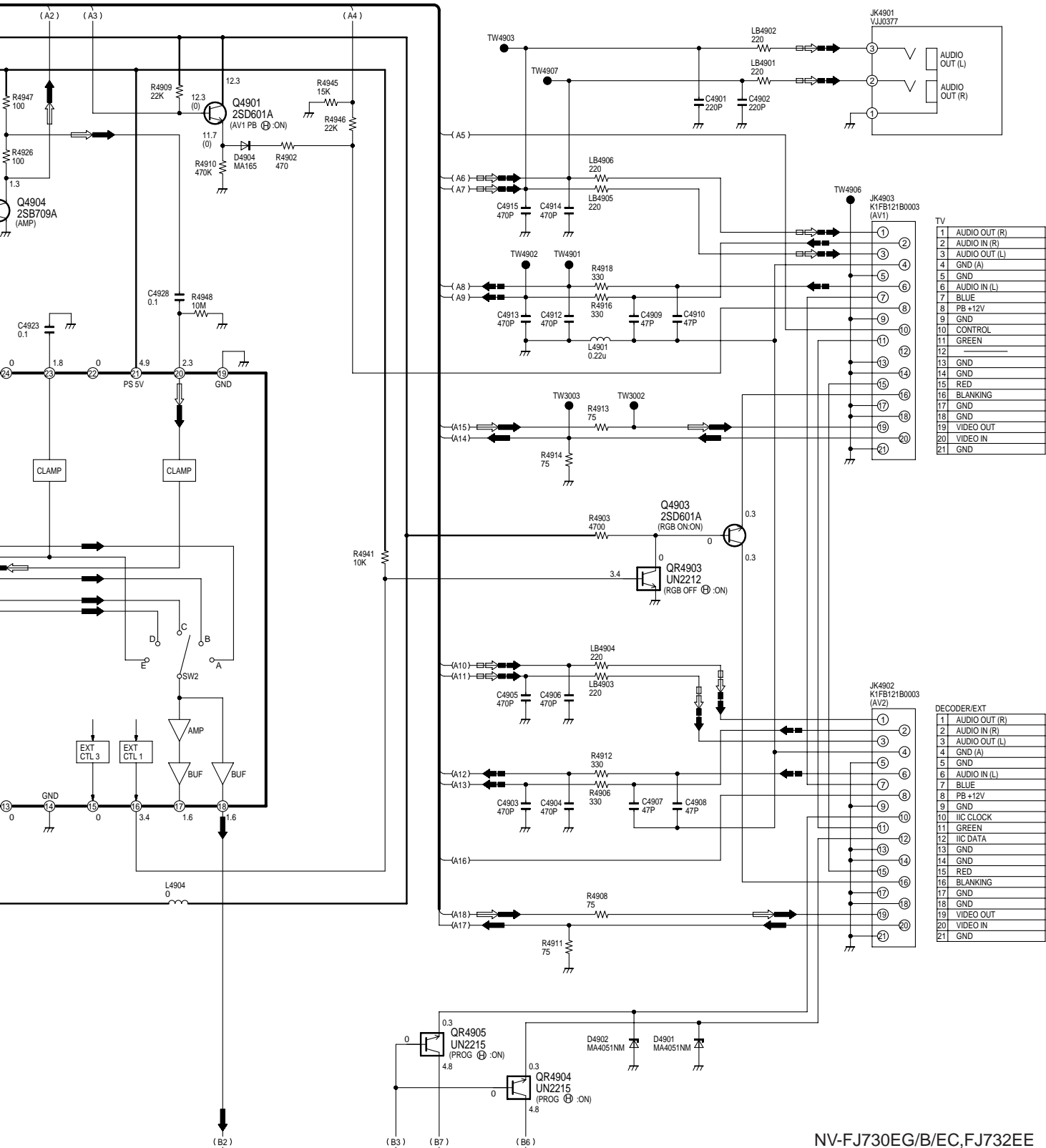

KEYS ON THIS DIAGRAM IS PLAYBACK MODE

NOTE: DO NOT USE ANY PART NUMBER SHOWN ON THIS SCHEMATIC DIAGRAM FOR ORDERING. WHEN YOU ORDER A PART, PLEASE REFER TO PARTS LIST.

NV-FJ730EG/B/EC, FJ732EE  
INPUT/OUTPUT SECTION  
SCHEMATIC DIAGRAM

# 8.8. TV DEMODULATOR PACK SCHEMATIC DIAGRAM

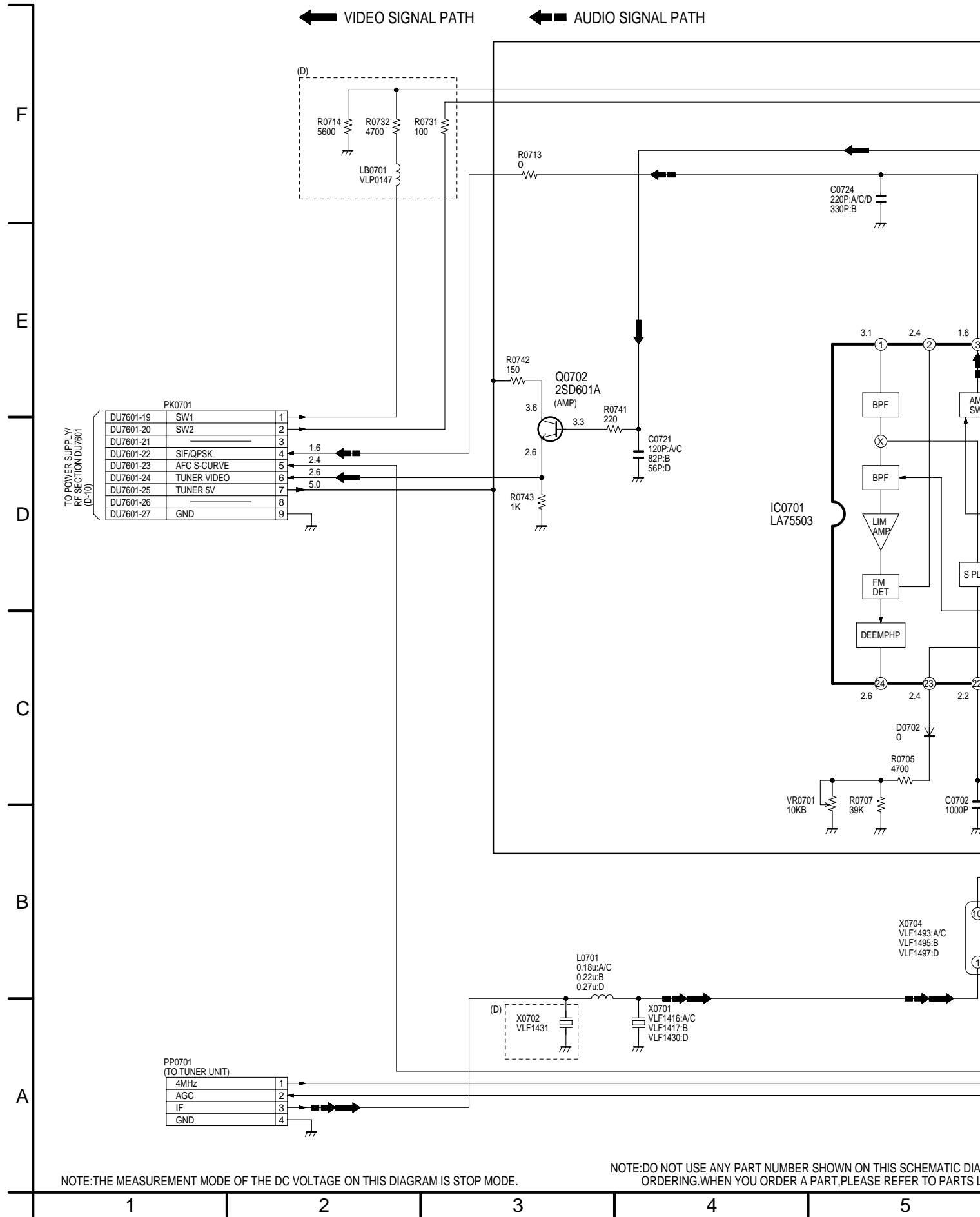

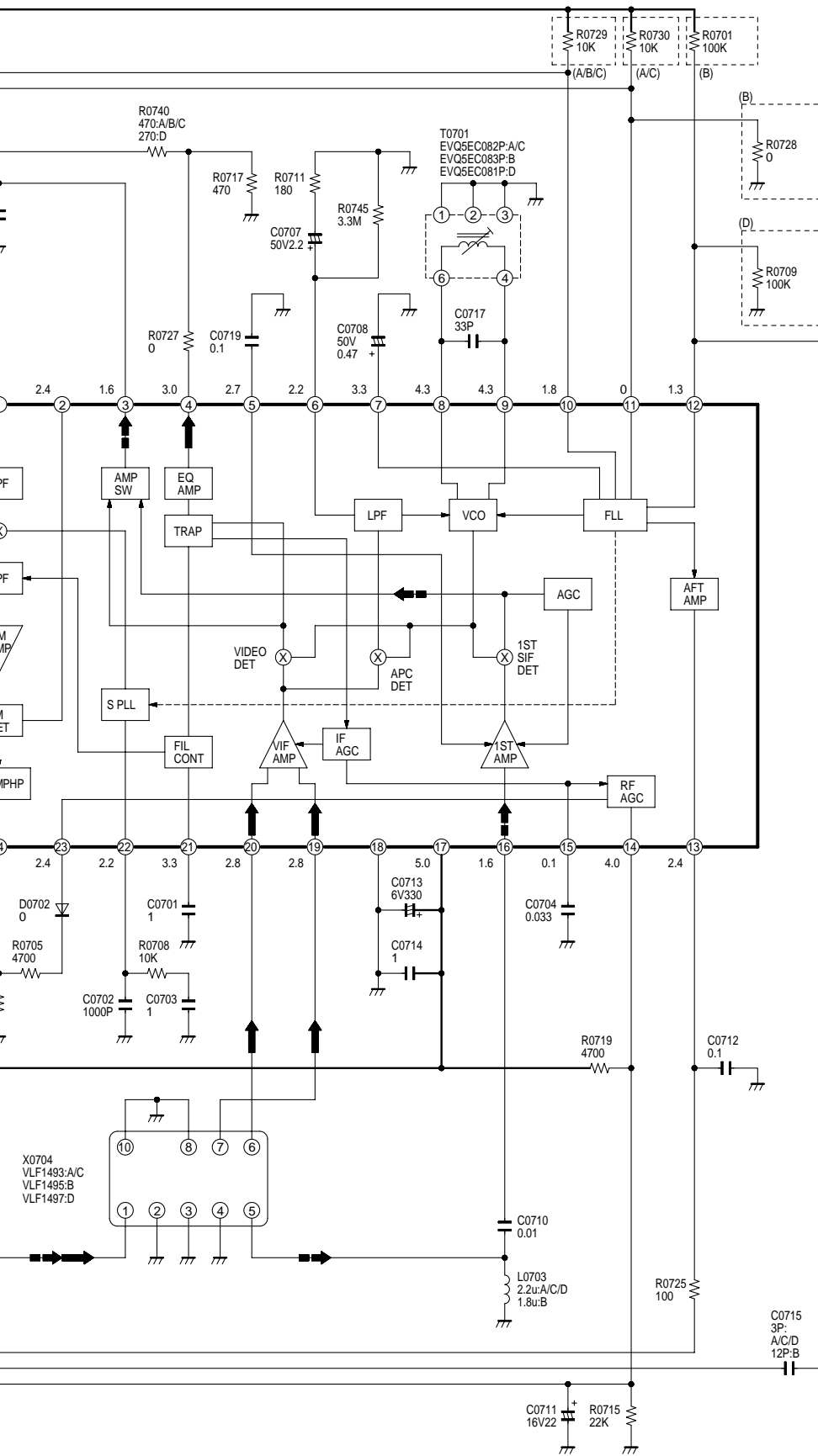

THIS SCHEMATIC DIAGRAM FOR  
REFER TO PARTS LIST.

NV-FJ730EG/B/EC, FJ732EE  
TV DEMODULATOR PACK SCHEMATIC DIAGRAM

# 8.9. DECODER PACK SCHEMATIC DIAGRAM (NV-FJ730EG)

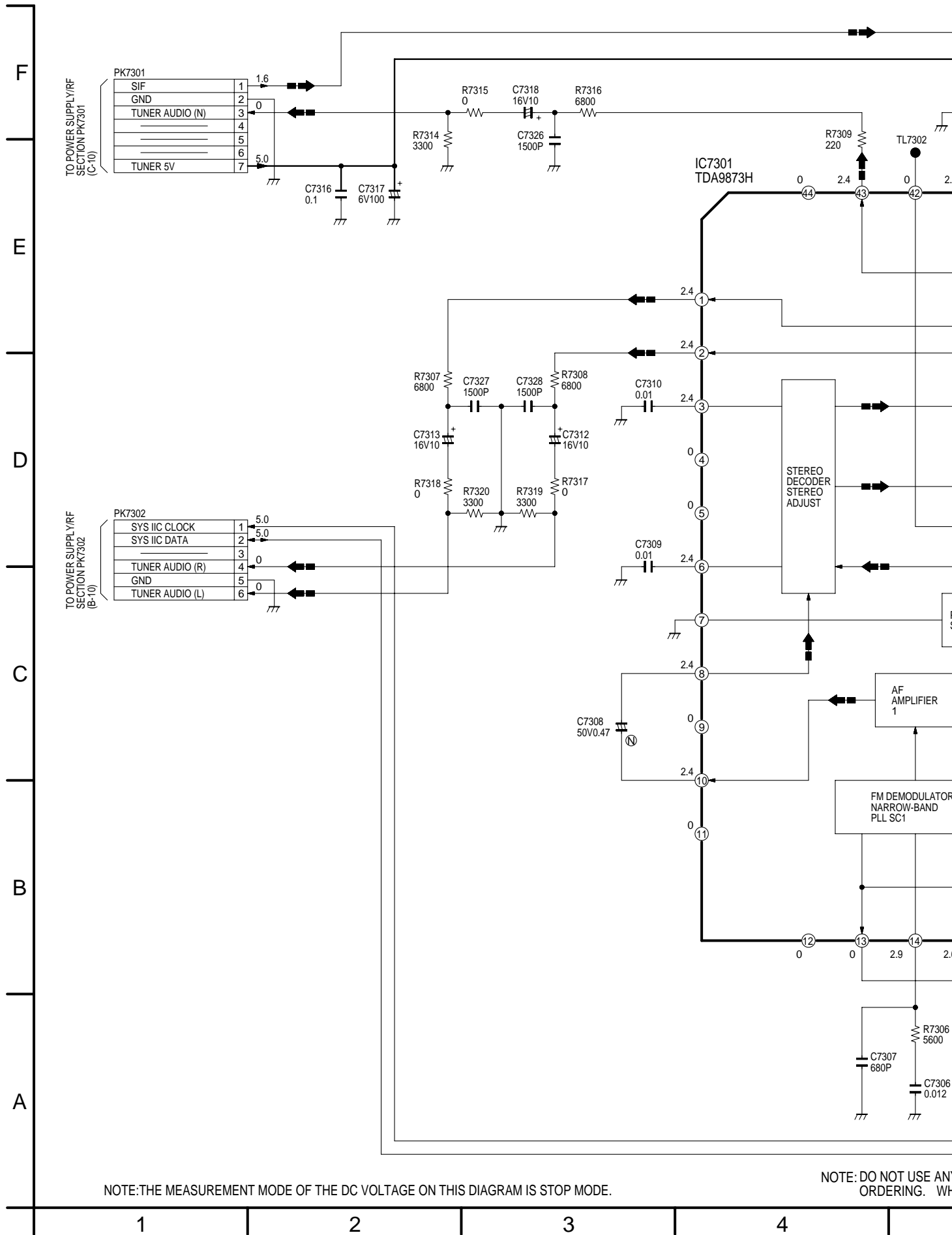

NOTE: THE MEASUREMENT MODE OF THE DC VOLTAGE ON THIS DIAGRAM IS STOP MODE.

NOTE: DO NOT USE ANY ORDERING. WH

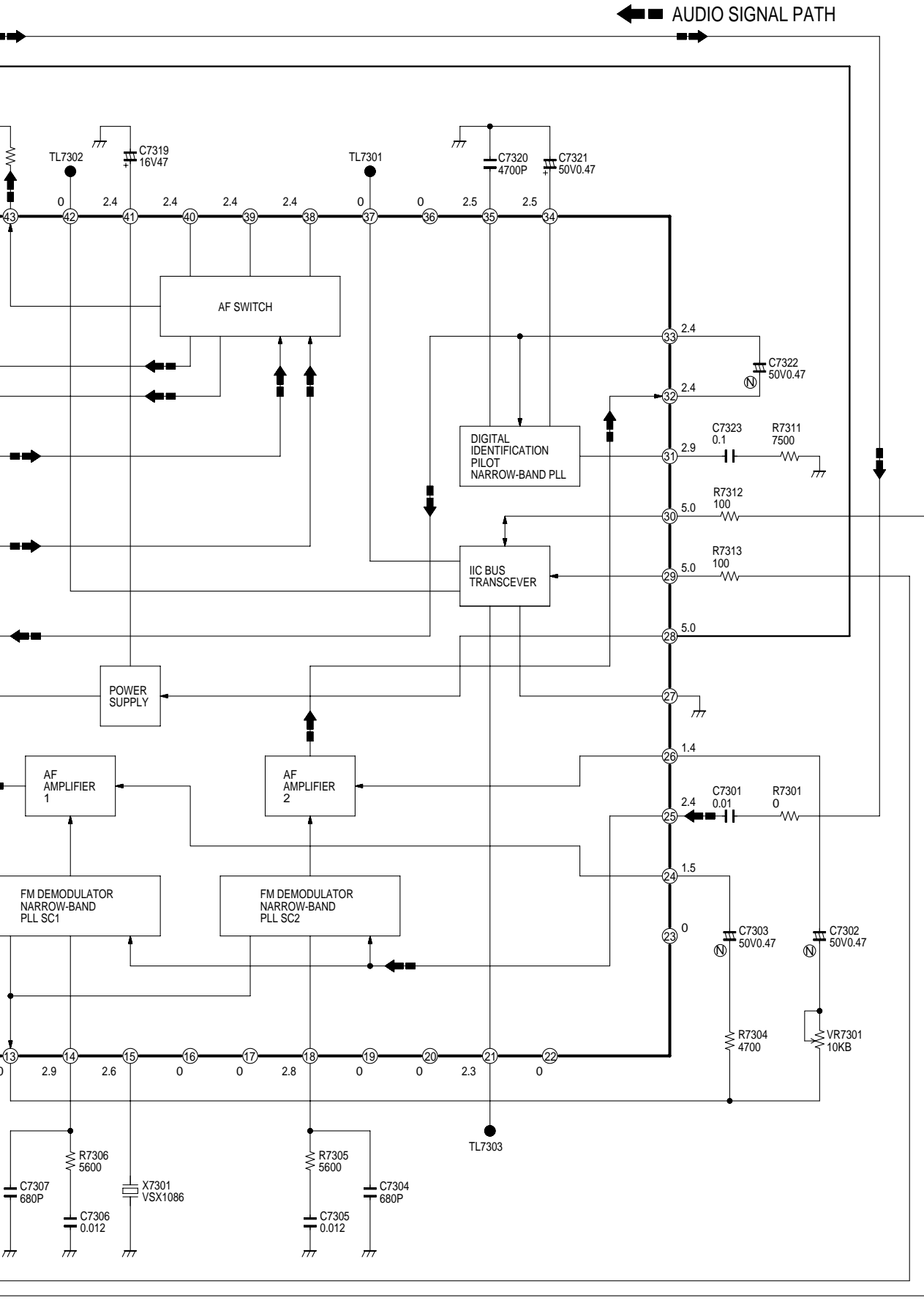

DO NOT USE ANY PART NUMBER SHOWN ON THIS SCHEMATIC DIAGRAM FOR ORDERING. WHEN YOU ORDER A PART, PLEASE REFER TO PARTS LIST.

NV-FJ730EG  
DECODER PACK SCHEMATIC DIAGRAM

5

6

7

8

# 8.10. NICAM DECODER PACK SCHEMATIC DIAGRAM (NV-FJ730B/EC, FJ732EE)

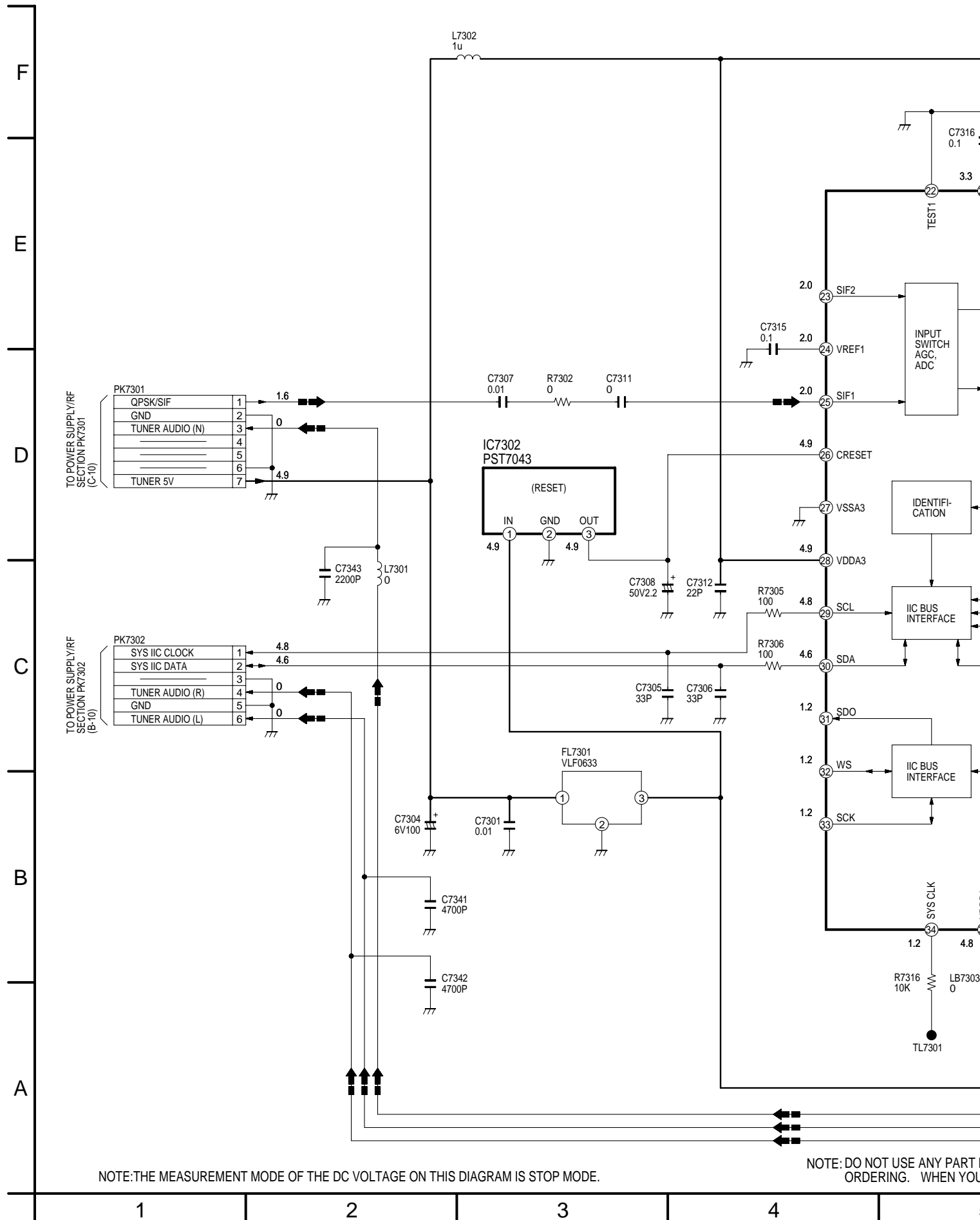



← AUDIO SIGNAL PATH

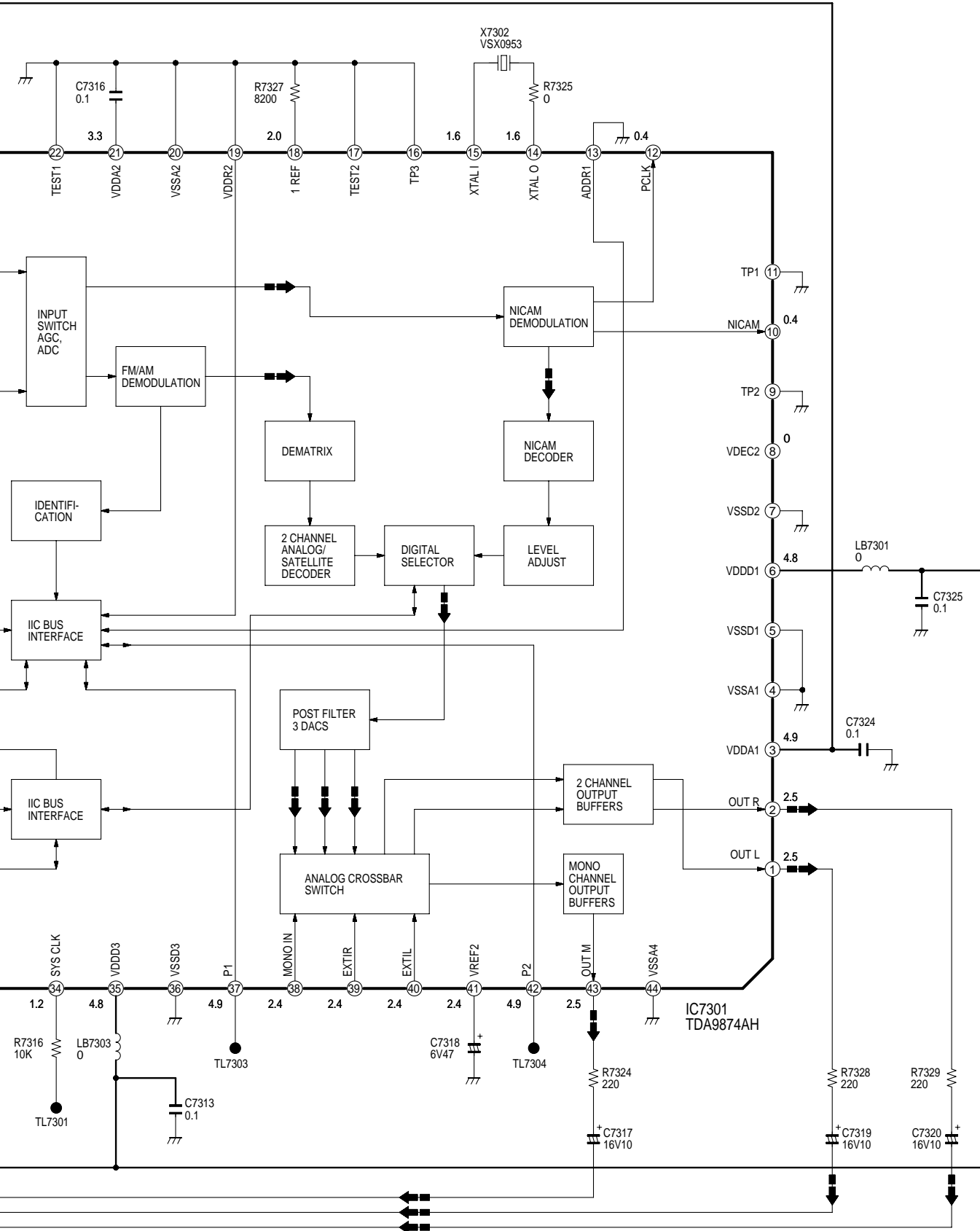

DO NOT USE ANY PART NUMBER SHOWN ON THIS SCHEMATIC DIAGRAM FOR ORDERING. WHEN YOU ORDER A PART, PLEASE REFER TO PARTS LIST.

NV-FJ730B/EC, FJ732EE  
NICAM DECODER PACK SCHEMATIC DIAGRAM

5

6

7

8

## 8.11. CYLINDER STATOR UNIT SCHEMATIC DIAGRAM

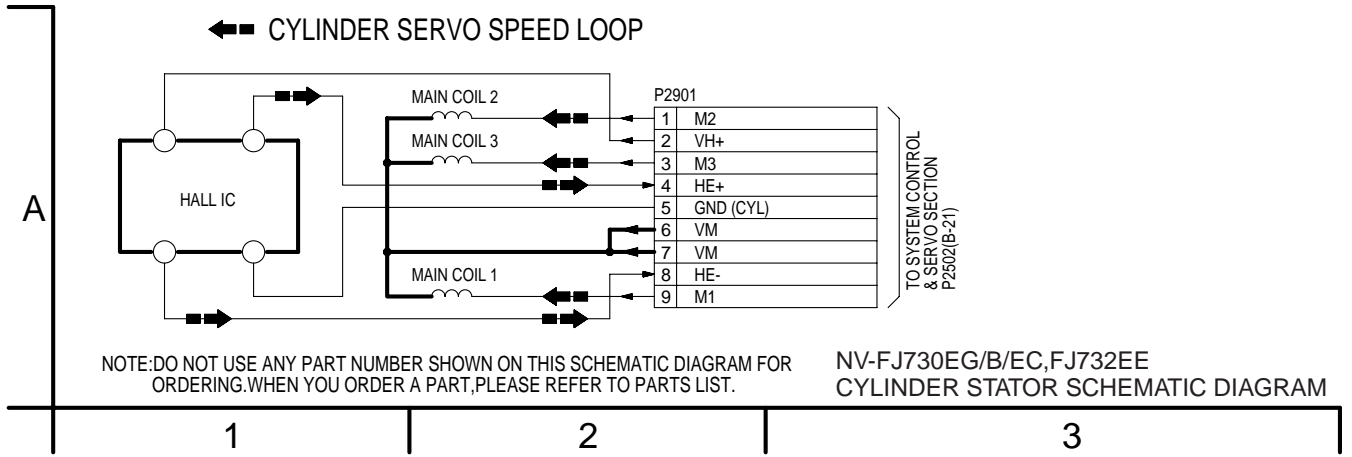

## 8.12. CAPSTAN UNIT SCHEMATIC DIAGRAM

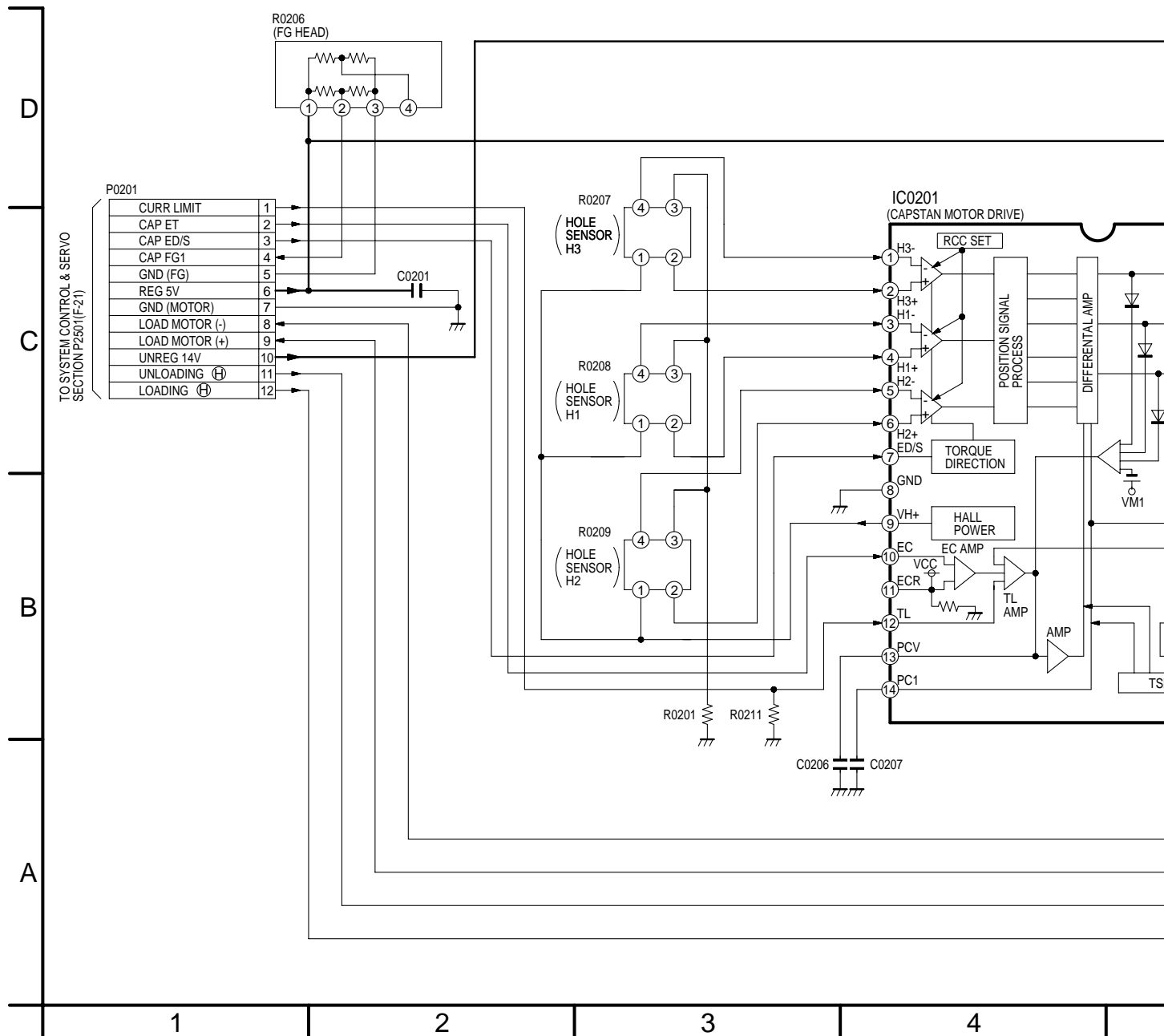

AM

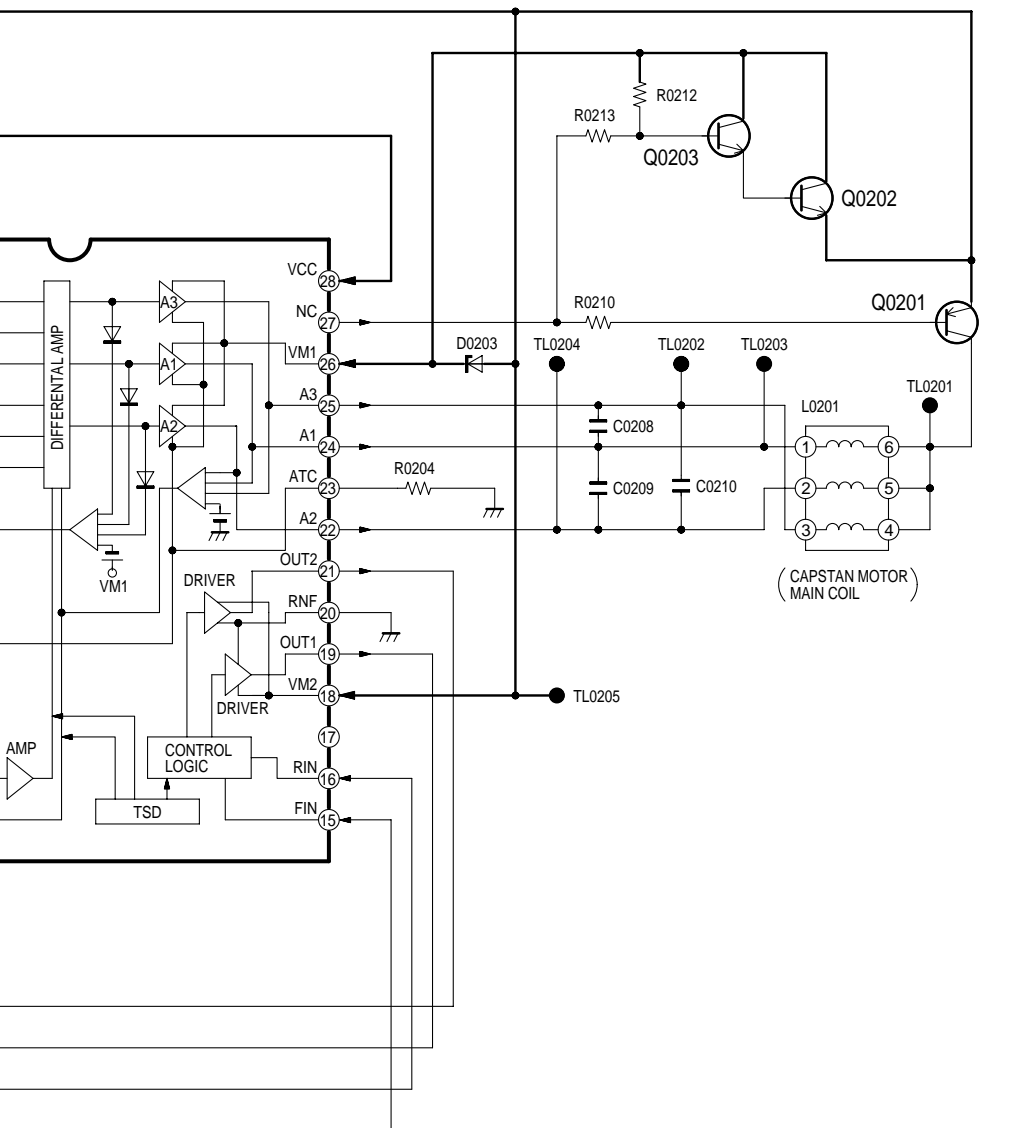

NV-FJ730EG/B/EC, FJ732EE  
CAPSTAN UNIT SCHEMATIC DIAGRAM

5

6

7

# 8.13. AV FRONT SCHEMATIC DIAGRAM

